

DrägerSensor IR

en

Infrared Gas Sensor
Instructions for Use

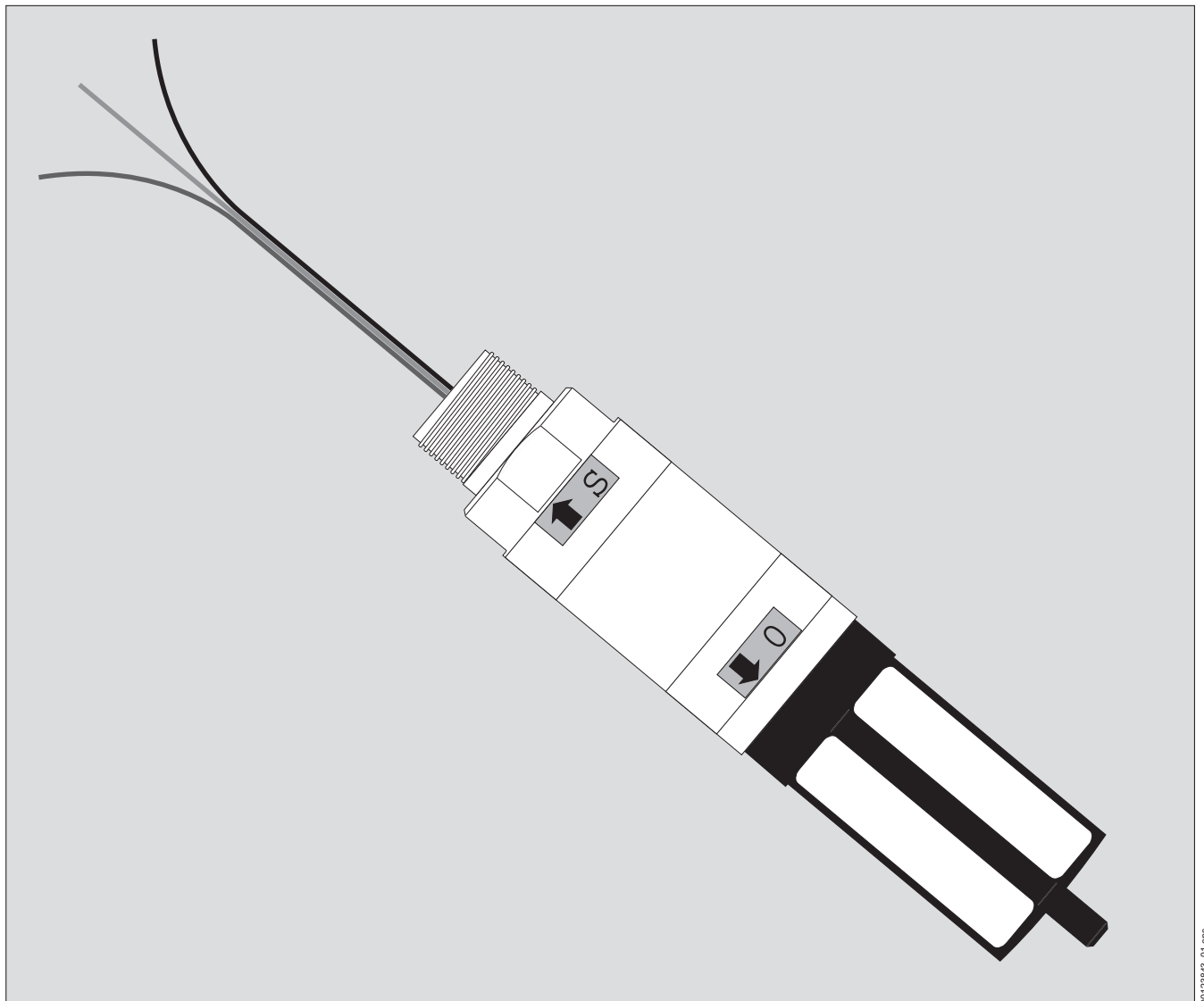

Contents

For Your Safety	3
Intended Use	4
Explosion-Protection Approvals	5
Installing the Gas Sensor	6
Mounting Location	6
Mechanical Installation	6
When used according to BVS 05 ATEX E 143 X, please note:	6
Terminal Box	6
Splash Guard and Calibration Adapter	7
Gas Exposure / Process Adapter	7
Dirt Deflector	7
Electrical Installation	8
When used according to BVS 05 ATEX E 143 X, please note:	8
Connection to Dräger REGARD SE Ex channel card	8
Connection to Dräger Polytron SE Ex channel card	9
Connection to other central devices	10
Commissioning	11
Operational Characteristics	12
Calibration	12
Configuration of the Gas Sensor via Magnetic Pin	15
Automatic Zerosetting	15
Manual Zero Calibration of the Output Signal	16
Manual Span Calibration of the Output Signal	18
Substitute Gas Calibration	19
Inverting the Output Signal	20
Checking the Signal transmission, Checking the Alarm Trigger and Displaying the Gas Category	21
Changing the Gas Category	23
Maintenance	24
Faults, Cause and Remedy	25
Technical Data	26
General Details	26
Measuring Technique Characteristics (Typical Values)	27
Cross Sensitivities	28
Dimensions	30
Description of Design	31
Order List	32
DrägerSensor IR infrared gas sensor	32
Accessories/Spare parts	32
ATEX - Approval	33
IECEX - Approval	53
UL - Approval	59
CSA - Approval	62
Declaration of Conformity	65

For Your Safety

Strictly follow the Instructions for Use

Any use of this gas sensor requires a full understanding and strict adherence to these instructions.

This gas sensor is only to be used for the purposes specified here.

Maintenance

Only trained service personnel may repair the gas sensor.

We recommend signing a service contract to have all maintenance jobs carried out by Dräger.

Always use original Dräger parts for maintenance.

Be sure to read the information provided in the chapter "Maintenance".

WARNING

Explosion hazard! Do not open sensor housing. There is a risk of ignition in explosive atmospheres. The sensor housing contains live parts. Unauthorised opening can lead to a safety-related failure of the sensor. The sensor does not contain any parts that can be serviced by the user.

Accessories

Only use accessories mentioned in the order list.

Safe Connection of Electrical Devices

Never connect this device to other electrical devices not mentioned in these Instructions for Use before consulting the manufacturer or an expert.

Use in Potentially Explosive Atmospheres

Devices or components used in potentially explosive atmospheres after being tested and approved according to national, European or international regulations may only be used under the conditions specified in the approval and under observation of relevant legal regulations.

Never modify the electrical equipment.

Never use defective or incomplete parts. Always take relevant regulations into account when repairing devices or components.

Safety symbols used in these Instructions for Use

These Instructions for Use contain a number of warnings for risks and hazards which might occur when using the instrument. These warnings contain signal words which will alert you to the degree of hazard you may encounter. These signal words and corresponding hazards are as follows:

⚠ WARNING

Indicates a potentially hazardous situation which, if not avoided, could result in death or serious injury.

⚠ CAUTION

Indicates a potentially hazardous situation which, if not avoided, could result in physical injury, or damage to the product or environment. It may also be used to alert against unsafe practices.

NOTICE

Indicates additional information on how to use the product.

Intended Use

The DrägerSensor IR infrared gas sensor is a device used for stationary, continuous monitoring of the concentration of carburetted, combustible gases and vapours in the ambient air.

The gas sensor is preconfigured for the gases methane, propane and ethylene. The operating range respectively covers 0 to 100%LEL (**L**ower **E**xplosion **L**imit). The measuring value is output with the help of a half bridge emulation as replacement for catalytic Ex sensors (pellistors).

The DrägerSensor IR infrared gas sensor is designed for use in rough ambient conditions and is suited for installation in hazardous areas of zones 1, 2, 21, and 22 according to the device categories 2G, 3G, 2D, 3D or Class I & II, Div. 1 for hazardous areas. For further information, please observe the installation instructions.

When used according to BVS 05 ATEX E 143 X, the DrägerSensor IR must be used with a gas transmitter approved for this purpose or a Dräger control unit.

In connection with a central device (e.g. Dräger Regard SE Ex):

- warning before explosive concentration level is reached
- automatic initiation of countermeasures which avert the explosion hazard (e.g. switching on a ventilation)
- device error warning

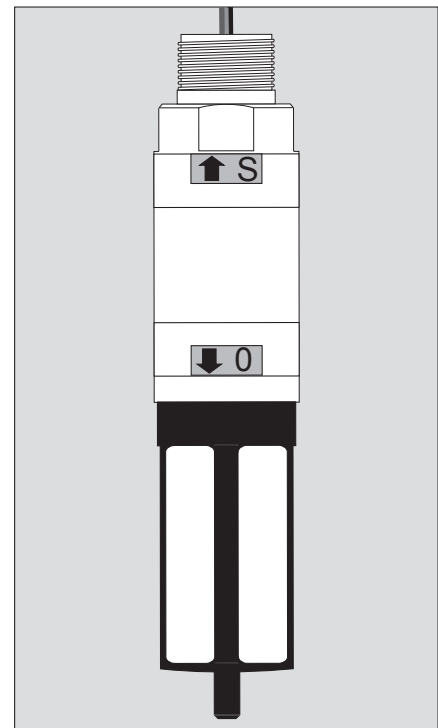



Explosion-Protection Approvals



The explosion-protection approvals are valid for use of the device in gas/vapour-air mixtures of combustible gases and vapours under atmospheric conditions. The explosion-protection approvals are not valid for use in oxygen-enriched atmospheres. Unauthorised opening of the enclosure invalidates the explosion-protection approval.

– ATEX



Typ IDS 0002:

 II 2G Ex db IIC T6 Gb  0158
 II 2D Ex tb IIIC T80°C Db IP6X
 $-40\text{ °C} \leq T_a \leq +65\text{ °C}$

Typ ISH 001X:

 II 2G Ex db IIC T6 Gb  0158
 II 2D Ex tb IIIC T80°C Db IP6X
 $-40\text{ °C} \leq T_a \leq +60\text{ °C}$

Typen IDS 0012 and ISH 000X:

 II 2G Ex db eb IIC T6 Gb  0158
 II 2D Ex tb IIIC T80°C Db IP6X
 $-40\text{ °C} \leq T_a \leq +65\text{ °C}$
 year of construction (by serial number) ¹⁾
 BVS 05 ATEX E 143X
 TÜV 19 ATEX 8433 X (measuring function)

– IECEx

Type IDS 0002:

Ex db IIC T6, Ex tb IIIC T80°C Db IP6X
 $-40\text{ °C} \leq T_a \leq +65\text{ °C}$

Typ ISH 001X:

Ex db IIC T6 Gb, Ex tb IIIC T80°C Db IP6X
 $-40\text{ °C} \leq T_a \leq +60\text{ °C}$

Typen IDS 0012 and ISH 000X:

Ex db eb IIC T6, Ex tb IIIC T80°C Db IP6X
 $-40\text{ °C} \leq T_a \leq +65\text{ °C}$
 BVS 05.0011X

– UL

(Underwriters Laboratories Inc.)

Typ IDS 0002:

Class I, Div. 1, Groups A, B, C, D
 Class II, Div. 1, Groups E, F, G



– CSA

Typ IDS 0002:

Class I, Div. 1, Groups A, B, C, D
 C22.2, No. 152



1) Configuration of serial numbers: The third letter of the serial number represents the year of manufacture: M = 2019, N = 2020, P = 2021, R = 2022, S = 2023, T = 2024, U = 2025, W = 2026, X = 2027, Y = 2028, Z = 2029 etc. (letters G, I, O, Q are omitted)
 Example: Serial number ARMB-0001: The third letter is M, i.e. the device was manufactured in 2019.

The appendix has a copy of the ATEX certificate, which offers relevant information on safety regulations under subjects such as "Subject matter and type", "Description", "Characteristic quantity" and "Terms/conditions of safe use".

Installing the Gas Sensor

Only trained service personnel (e.g. of Dräger) may install the gas sensor under observation of relevant regulations.

Installation and commissioning are described in "DrägerSensor IR Installation Instructions", supplied with the gas sensor.

Mounting Location

The protecting effect of the gas sensor depends on the selection of the mounting location. By taking the site's air flow conditions into account, the best possible mounting location should be chosen as close as possible to where a decisively noticeable rise in gas concentration can be expected in case of a leakage, i. e.

- as close as possible to the potential leakage place
- when monitoring gases and vapours which are lighter than air:
above the potential leakage place
- when monitoring gases and vapours which are heavier than air:
near to ground.

In addition, it must be assured that:

- the air circulation in the gas sensor vicinity is not hindered
- the danger of mechanical damage is reduced as far as possible
- the gas sensor is sufficiently accessible for maintenance purposes. Especially the configuration via magnetic pin requires a clearance of approx. 20 cm around at least half of the sensor perimeter.

The gas sensor can be mounted horizontally as well as vertically.

Mechanical Installation

When used according to BVS 05 ATEX E 143 X, please note:

- The gas sensor type IDS 0002 (NPT) can be attached to casings with the type of protection flameproof enclosure "d" that have a free volume of 2 litres and a reference pressure that does not exceed 20 bar. The mechanical strength of the attachment and the explosion and construction-related testing of the connection thread must be carried out within the framework of the approval process of the electrical equipment to which the sensor is attached.
- The gas sensor type IDS 0012 (metric thread) is designed for attachment on a casing with the type of protection increased safety "e". The mechanical strength and the degree of protection IP 6X of the attachment must be ensured during approval of the electrical equipment to which it is attached.
- The junction boxes of the gas sensors IDS 00** must feature sufficient mechanical stability to ensure that the vibrations transmitted to the sensor by the casing are not amplified.

Terminal Box

The gas sensor is designed to be directly attached to a terminal box. Approved connector boxes of the following makes are available as gas sensor accessories: Ex d (explosion proof, 3/4" NPT) and Ex e (increased safety, M25) - (see "Order List" on page 32).

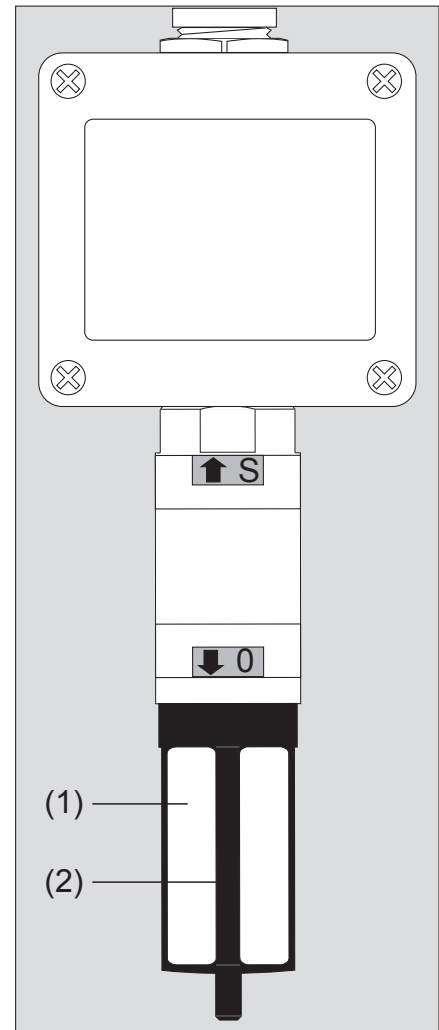

- To maintain the housing protection class, the enclosed O-ring seal must be used for an Ex e-type explosion protection connection.
Use a thread locking adhesive, e.g. Loctite® to prevent the M25 nut (torque of 15 Nm ±3 Nm) from self-loosening.
- Use approved plugs to close any unused cable entry openings at the terminal box.

Splash Guard and Calibration Adapter

We recommend using the supplied accessories - splash guard **(1)** and calibration adapter **(2)** - to increase protection against water jets and contamination. The splash guard is held by a fixture provided with screw-thread, which is also used as calibration adapter. Make sure that the calibration adapter is correctly seated. To this end, manually tighten the calibration adapter to a point where the sealing line leaves a permanent mark on the splash guard.

Gas Exposure / Process Adapter

(see "Accessories/Spare parts" on page 32)

For continuous flow operation of the gas sensor, the calibration adapter can be replaced with an optional gas exposure / process adapter.

- Suitable for flow rates between 1 and 3 L/min.
- Within the specified technical measurement characteristics suitable for pressure differences relative to ambient pressure of up to ±300 hPa.
- Use external pump to ensure gas flow.
- External flow monitoring required.
- Also suitable for calibration gas application.

Assembly:

- Unscrew the calibration adapter from the gas sensor. While doing so, leave splash guard on the gas sensor.
- Screw gas exposure / process adapter onto the gas sensor and tighten firmly by hand.
- In the case of pipelines and hose lines carrying gas ensure that there is stability with regard to ambient conditions and material compatibility for the substances flowing through them.
- With regard to the length of the pipelines or hose lines observe the increase in the response time.
- Ensure the compatibility of the connection spouts to be used regarding the pipeline and hose line dimensions.
- Check the gas-carrying system for leaks, e.g. with a soap bubble test.

Dirt Deflector

(see "Accessories/Spare parts" on page 32)

Instead of the calibration adapter, a double-walled dirt deflector can optionally be fitted to the gas sensor. This is recommended for locations with a high rate of contaminations through salt crusts, oil films, resin or similar substances. In addition to the dirt deflector, the use of a splash guard is strongly recommended.

- Also suitable for calibration gas application.

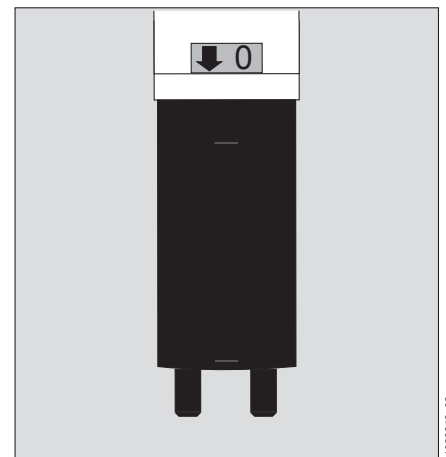

01323843_02.eps

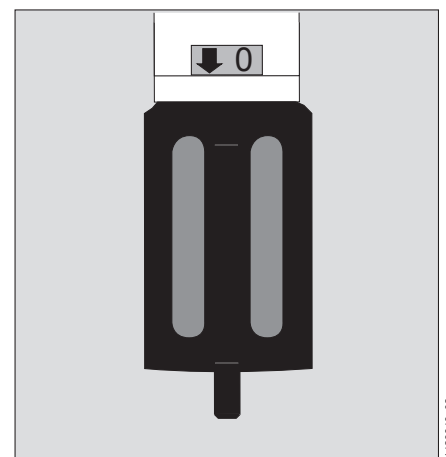

01423843_02.eps

Assembly:

- Unscrew the calibration adapter from the gas sensor. While doing so, leave splash guard on the gas sensor.
- Screw dirt deflector on the gas sensor, and apply as firmly by hand that it leaves a lasting impression of his seal lines in the splash guard.

Electrical Installation

NOTICE

If present: If the connector of the gas sensor is not required, it must be removed prior to the electrical installation. To do so, cut the cables with a suitable tool directly in front of the connector, strip the insulation, and attach suitable ferrules.

The entire wiring must correspond with applicable local regulations concerning the installation of electrical devices in potentially explosive atmospheres. In case of doubt, consult the responsible authorities before installing the device. We recommend a three-core, screened connection cable (mesh wire shield with a shielding factor of $\geq 80\%$)

NOTICE

Earth leakages on two phases can cause EMC problems. To avoid these problems, the cable screen may only be connected to earth potential on one side (either at the central unit or at the gas sensor). In most cases, connecting the cable screen to the PE terminal of the terminal box has proven to work better than connecting it to the central device.

- The cables for the sensor are sealed before leaving the factory.
- If the corresponding connection is available. Electrically connect the terminal box to earth.
- For installation in conduit: cast conduit seals and allow to harden.
- Do not connect gas sensor and power supply before the wiring has been installed and tested.
- When connecting, observe the correct polarity of the gas sensor (protection against polarity reversal up to max. 1 A)
- When installing a complete set (see "Order List" on page 32):
Depending on the housing type of the terminal box there are the following permissible conductor cross sections:

Order No. 68 11 165: 1.0 to 2.5 mm ²	Order No. 68 11 275: 0.5 to 4.0 mm ²	Order No. 68 11 185: 0.2 to 4.0 mm ²
---	---	---

When used according to BVS 05 ATEX E 143 X, please note:

- After attachment of the sensor to a casing with the type of protection increased safety "e", the air gaps and creepage distances must comply with the requirements specified in 4.3 (Table 1) or 4.4 of EN 60079-7. The single core cables must be routed and connected in a way that is mechanically protected and complies with the temperature resistance of the wires as specified in 4.5, 4.7.2 and 4.8 of EN 60079-7.
- From an electrostatic point of view (transition resistance $< 10^6$ ohm) the sensor casing must be conductively connected to the equipotential bonding of the casing to which it is attached as soon as it is attached. If equipotential bonding is required, it must be provided with the attachment.

Connection to Dräger REGARD SE Ex channel card¹⁾

- When the current amounts to 200 mA (recommended), the line resistance must not exceed 10 Ohm per core. When the current amounts to 400 mA, the line resistance must not exceed 8 Ohm per core. For this reason, the various wire cross-sections may have the following maximum line lengths

Wire cross-section	0.5 mm ² (36 Ohm/km)	0.75 mm ² (24 Ohm/km)	1.0 mm ² (18 Ohm/km)	1.5 mm ² (13 Ohm/km)	2.5 mm ² (8 Ohm/km)	4.0 mm ² (5 Ohm/km)
Maximum cable length with supply current of 200 mA	270 m	410 m	550 m	760 m	1250 m	2000 m
Maximum cable length with supply current of 400 mA	220 m	330 m	440 m	610 m	1000 m	1600 m

1) The measuring function for the explosion protection according to EN 60079-29-1 is proven, see EC-Type Examination certificate DMT 02 ATEX G 002X and associated additions.

- Connect terminals 1, 2, and 3 of the measuring head with terminals 1, 2, and 3 of the chassis

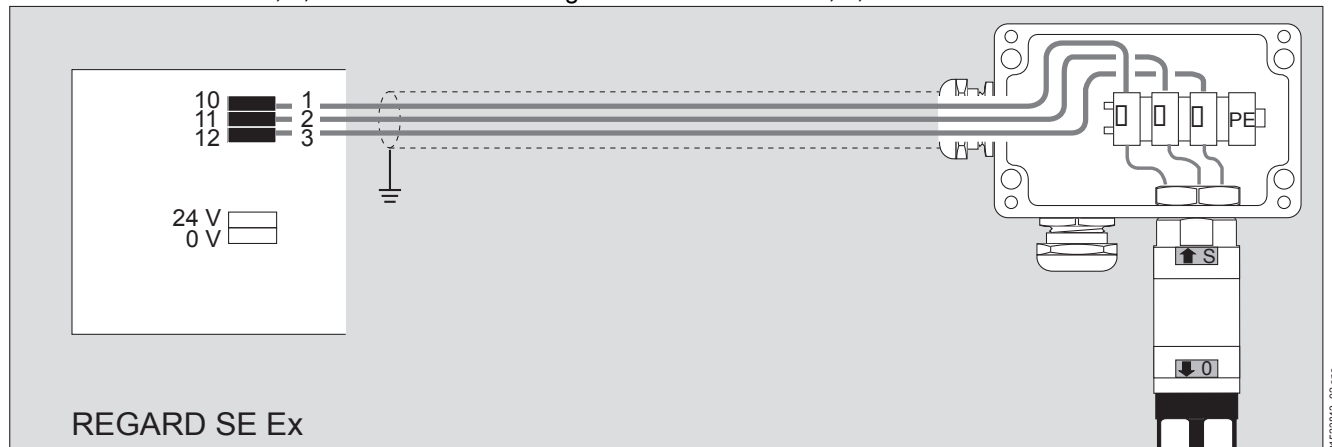

Colour assignment 1 = brown; 2 = yellow; 3 = black

- Carefully connect the measuring line.
Select the measuring lines according to the installation instructions for each operating temperature range.

Connection to Dräger Polytron SE Ex channel card¹⁾

- The maximum line resistance depends on the set supply current.
When the current amounts to 200 mA (recommended), the line resistance must not exceed 17 Ohm per core.
When the current amounts to 390 mA, the line resistance must not exceed 10 Ohm per core.
For this reason, the various wire cross-sections may have the following maximum line lengths:

Wire cross-section	0.5 mm ² (36 Ohm/km)	0.75 mm ² (24 Ohm/km)	1.0 mm ² (18 Ohm/km)	1.5 mm ² (13 Ohm/km)	2.5 mm ² (8 Ohm/km)	4.0 mm ² (5 Ohm/km)
Maximum cable length with supply current of 200 mA	470 m	700 m	940 m	1,300 m	2,100 m	3,400 m
Maximum cable length with supply current of 400 mA	270 m	410 m	550 m	760 m	1250 m	2000 m

- Connect terminals 1, 2, and 3 of the measuring head with terminals 1, 2, and 3 of the chassis

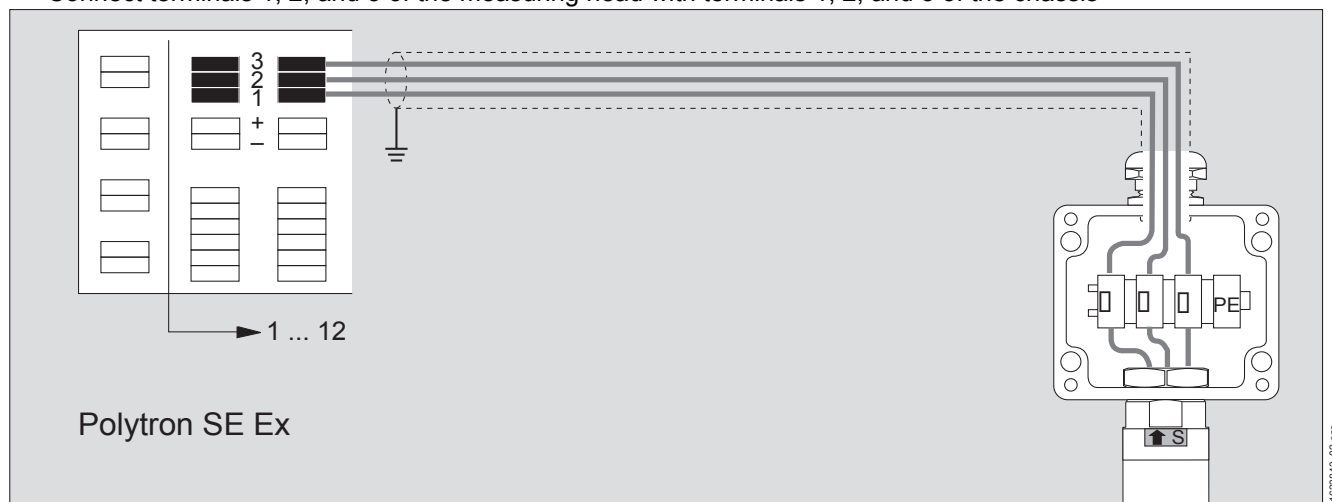

1) The measuring function for the explosion protection according to EN 60079-29-1 is proven, see EC-Type Examination certificate BVS 05 ATEX E 143X and associated additions.

Colour assignment 1 = brown; 2 = yellow; 3 = black

- Carefully connect the measuring line.
Select the measuring lines according to the installation instructions for each operating temperature range.

Connection to other central devices ¹⁾

Colour code of connecting terminals and/or leads at the gas sensor:

Terminal 1 (brown) = + (supply)
Terminal 2 (yellow) = output signal (concentration-dependent medium potential of the half bridge)
Terminal 3 (black) = – (common reference potential)

Connected values:

For field operation, we recommend supplying a constant current between 200 and 400 mA DC to the gas sensor.

Alternatively, the gas sensor can be operated with a constant voltage between 2 and 5 V DC. In this case, the cable length amounts to max. 5 m. This operating mode is intended for settings at service centres.

Power consumption amounts to max. 1 W for both operating modes.

The gas sensor automatically detects a constant current supply or a constant power supply when the central device is switched on.

The leads between central device and gas sensor must have a sufficiently low resistance to ensure the correct supply voltage at the gas sensor. For constant current mode, the maximum resistance per core is calculated as follows:

$$R = \frac{P_C - 1 \text{ W}}{2 \times I_C^2}$$

with R: maximum resistance per core

I_C : constant current set at central device

P_C : Performance of the central device with I_C (according to manufacturer's instructions)

Example:

With $I_C = 200 \text{ mA}$, $P_C = 1.6 \text{ W}$, the result is a maximum resistance per core of $R = 7.5 \text{ } \Omega$.

With cable lengths per core of 1500 m, the resistance per unit length $R' = 50 \text{ } \Omega / 1500 \text{ m} = 33 \text{ } \Omega/\text{km}$ may not be exceeded.

NOTICE

Cable resistance deviations caused by temperature influences, transition resistances of terminals, etc. can also contribute to the fact that the calculated cable length can not be fully used.

To keep cable losses to a minimum, we recommend setting the constant current as low as possible at the central device.

- In constant voltage mode, unequal lead resistances can lead to a deviation between the output signal of the gas sensor and the gas concentration displayed by the central device as well as to a periodic fluctuation of the output signal. In this case, sensor signal and central device display must be synchronised as described under "Displaying the gas category" on page 21. Common central devices are equipped with standard low-pass filters (with a typical time constant of 10 seconds) which usually smoothen the periodic fluctuations of output signals.

¹⁾ The measuring function for the explosion protection is not proven.

Commissioning

The DrägerSensor IR infrared gas sensor is preconfigured and ready for use after installation.

- Deactivate the alarm call to the central device to avoid false alarms.
- When the supply voltage is applied, the gas sensor automatically performs a self check (10 seconds), then automatically uses the factory-preset calibration (see page 12) and gas category.
For the duration of the self test, the gas sensor issues a signal of approx. –15 %LEL. (Remark: If the gas sensor and the central device are not synchronised, the value indicated at the central device might deviate).
- Wait for the running-in period of one minute to expire. No settings can be changed at the gas sensor during this period. For the duration of the running-in period, the gas sensor issues a signal of approx. –15 %LEL.
- Check signal transmission and adjust if required (see "Checking the signal transmission, checking the alarm trigger and displaying the gas category" on page 21).
- Check setting of the gas category for the intended use. If required, set the gas category(see "Changing the gas category " on page 23).
- Check the calibration of the gas warning system (see "Calibration" on page 12).
- Reactivate the alarm call to put the system back to normal operating state.

NOTICE
To prevent moisture condensation on the optic surfaces of the device, parts of the sensor housing are heated from the inside. This can increase the surface temperature by approx. 5 °C.

Operational Characteristics

The gas sensor generates an output signal which is proportional to the measured gas concentration (within the specification for the output signal). The factor of proportionality between displayed value and the measured gas concentration is determined by the span calibration of the gas sensor (see "Span calibration" on page 17).

The gas sensor regularly runs self tests for numerous internal functions. As soon as a divergence from normal operation is detected, the device will issue a fault message.

Output Signals of the Device in Delivery State:

Display of	Output Signal
Inlet signal (during self check and running-in period)	49.7 % of supply voltage (corresponds to approx. -15 %LEL)
zero point	50 % of supply voltage
full scale value	52 % of supply voltage
under-range and span gas signal (start and end of DrägerSensor IR calibration routine)	49.8 % of supply voltage (corresponds to approx. -10 %LEL)
fault (with non-inverted output signal)	<20 % of supply voltage (simulates a line break and/or short circuit)
fault (with inverted output signal)	55 % of supply voltage

Calibration

A functional check and - if necessary - a calibration must be carried out regularly for gas warning systems (see page 24, Maintenance).

The calibration of a gas warning system equipped with DrägerSensor IR should be carried out at the central device of the gas warning system. The procedure for calibration is described in the operating manual of the central device.

However, it is possible to carry out calibrations and settings directly at the DrägerSensor IR. This is required in the following cases:

- The zero point of the optical measuring unit of the DrägerSensor IR is to be synchronised.
- A substance with a particularly low calibration factor (less than 0.5) is to be detected.
- The central device does not have the required setting possibilities to adjust the zero point and/or span.
- The parameters set at the DrägerSensor IR (e.g. the gas category) are to be displayed or changed.

Zero gas and test gas are to be applied for functional check and calibration of the DrägerSensor IR. To this end, the gas is applied either with

- the calibration adapter in connection with the splash guard (see page 7, part of the scope of delivery) or
- the dirt deflector in connection with the splash guard (see order list) or
- the gas exposure / process adapter (see page 7 and order list).

The required gas flow rate for functional check and calibration is as follows:

- 0.5 to 1 L/min. for the calibration adapter with splash guard and the dirt deflector with splash guard in closed rooms at wind speeds up to 5 m/s (3 Beaufort),
- 1 to 2 L/min. for the calibration adapter with splash guard and the dirt deflector with splash guard at wind speeds up to 27 m/s (10 Beaufort),
- 0.5 to 3 L/min. for the gas exposure / process adapter.

NOTICE

Make sure that the calibration adapter is correctly seated. To this end, manually tighten the calibration adapter to a point where the sealing line leaves a permanent mark on the splash guard.

Nitrogen, or - alternatively - synthetic air or fresh air (hydrocarbon content <50 ppm) can be used for zero point calibration.¹⁾

Commercially available calibration gas can be used to calibrate the respective gas category (methane, propane, ethylene). The highest accuracy is achieved using test gas concentrations of 40 to 70 percent of the measurement span.

The DrägerSensor IR can also be used for measuring other gases than mentioned above. For detailed information, refer to "Substitute Gas Calibration" on page 19.

- Select the measured gas in the corresponding table and determine the corresponding gas category.
- Set the gas sensor to the determined gas category.

Where possible, calibration gas should match with the measured gas for span calibration. In exceptional cases, span calibration can be carried out using a suitable substitute gas and the associated calibration factor. The suitable substitute gas as well as the associated calibration factor is shown in the table "Substitute Gas Calibration" on page 19.

- Select the substitute gas (gas category) and the calibration factor in table "Substitute Gas Calibration" on page 19.
- Multiply the concentration of the substitute gas by the calibration factor to calculate the gas concentration to be set on the central device of the gas warning system.

Example:

Measured gas:	n-octane
Gas category:	Propane (see table "Substitute Gas Calibration", page 19)
Calibration factor:	1.8 (see table "Substitute Gas Calibration", page 19)
Span gas concentration:	40 %LEL propane (bottle concentration)
Setting at the central device:	40 %LEL x 1.8 (calibration factor) = 72 %LEL

2nd Example:

Measured gas:	methanol
Gas category:	Ethylene (see table "Substitute Gas Calibration", page 19)
Calibration factor:	0.2 (see table "Substitute Gas Calibration", page 19)
Span gas concentration:	40 %LEL ethylene (bottle concentration)
Setting at the sensor:	40 %LEL x 0.4 (proportional calibration factor) = 16 %LEL
Setting at the central device:	16 %LEL x (0.2:0.4) (remaining calibration factor) = 8 %LEL

⚠ CAUTION

Never inhale test gas. Danger to health!

Observe the safety information in the corresponding safety data sheets. Ensure that gases are vented or otherwise guided outside the building.

1) For applications according to BVS 05 ATEX E 143 X, dry test gas may also be used.

NOTICE

Calibrating the gas sensor and the central device at the same time can detune the gas sensor and the central device in opposite directions which in turn can reduce both the measuring range which can be represented and the calibration range of the entire system. Example: The central device has a zero point adjustment range of ± 20 %LEL and is detuned by -20 %LEL. The gas sensor is detuned by $+20$ %LEL at the zero point to get a zero display for the entire system. Result: A negative drift of the gas sensor can now no longer be compensated at the central device.

Configuration of the Gas Sensor via Magnetic Pin

A magnetic pin can be used to change the settings of the DrägerSensor IR (see order list, page 32) as follows:

- Automatic zero setting.
- Manual zero calibration of the output signal. ¹⁾
- Manual span calibration of the output signal. ¹⁾
- Invert the output signal. ¹⁾
- Checking the signal transmission, checking the alarm trigger and displaying the gas category. ¹⁾
- Changing the gas category. ¹⁾

Automatic Zero setting

- Deactivate alarm activation of the central device.
- Expose the gas sensor to nitrogen, synthetic air, resp. fresh air via calibration adapter and wait until measurement value stabilises.
- Place the magnetic pin onto the sensor surface area marked by the "  " icon and hold it there (within the black frame) for at least five seconds. After five seconds, the output signal of the gas sensor changes to the display of the span gas signal (display change by approx. -10 %LEL) for as long as the magnetic pin is held against it. At the same time, an automatic zero setting of the optical measuring unit is carried out.
- Remove the magnetic pin. After 30 seconds, the device exits the automatic zero setting routine. As confirmation of the automatic zero setting, the output signal changes back to the span gas signal (display change by approx. -10 %LEL). This signal is indicated for the same period of time as when starting the automatic zero setting routine.
- Activate alarm activation of the central device.

¹⁾ A second person is required as helper for these tasks.

Manual Zero Calibration of the Output Signal ¹⁾

- Deactivate alarm activation of the central device
- 1 Expose the gas sensor to nitrogen, syringe adapter and wait until measurement value is 0.
- 2 Place the magnetic pin onto the sensor and hold it there (within the black frame). After 30 seconds, the output signal of the gas sensor changes to 0 mA (display change by approx. 0.5 mA). At the same time, the zeroing measuring unit is carried out.
- 3 Remove the magnetic pin. The output signal returns to the previous display. The device is now ready for use. While in this routine, the display will detect whether the magnetic pin is placed on or "↑S" icons.
- 4 Adjust the zero point signal by placing the magnetic pin marked by the "↓0" or "↑S" icons.
- 5 Remove the magnetic pin. The device terminates the zero point calibration routine after 30 seconds without further settings being carried out. As confirmation of the successful calibration, the output signal changes back to the span gas signal (3 mA). This signal is indicated for the same period of time as when starting the zerosetting calibration routine.
- 6 Terminate exposure to gas.
- Reactivate alarm activation of the central device

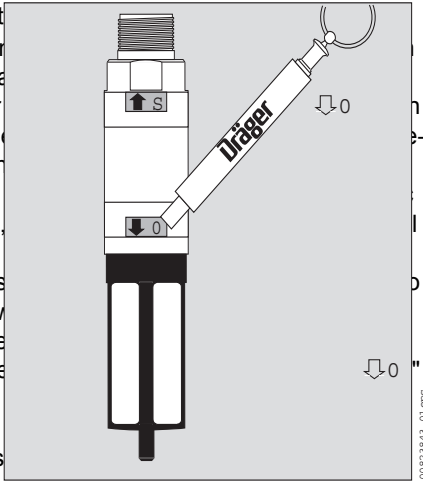

1) The values in %LEL mentioned in this section are only valid for gas warning systems that are calibrated for the measured gases methane, propane or ethylene. The actual LEL values [%] may deviate from the mentioned LEL values [%] on gas warning systems which have not yet been calibrated or which were calibrated with a substitute gas and a calibration factor.

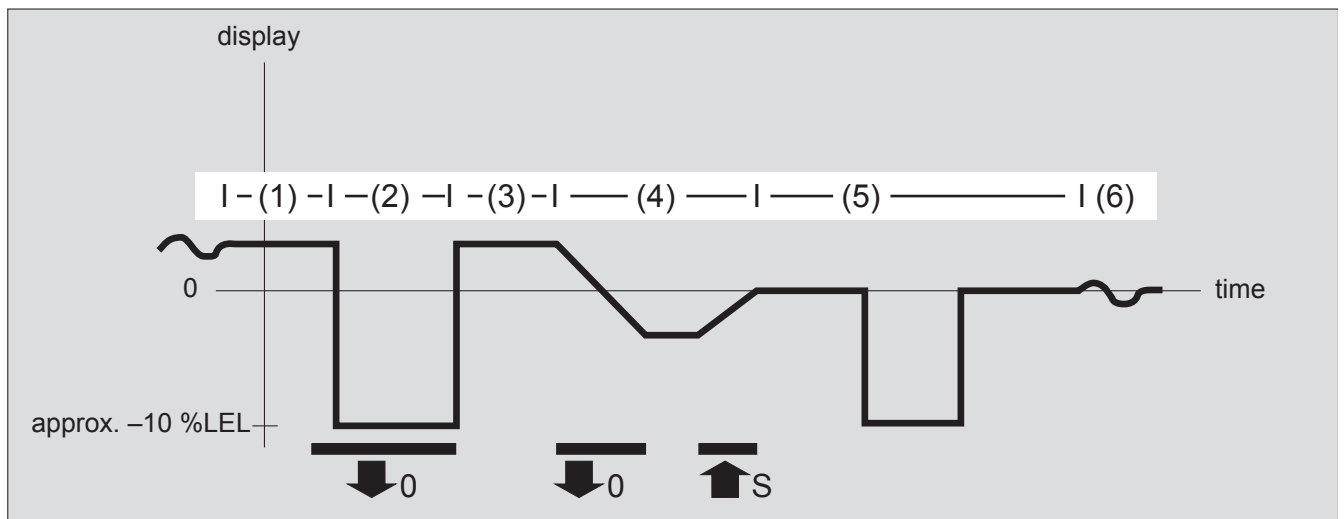
**NOTICE**

The calibration is automatically terminated and new calibration parameters are not saved if the gas concentration measured by the gas sensor changes during the calibration procedure (e.g. because the calibration gas cylinder fell empty during the calibration procedure). In this case, the gas sensor returns to normal operation without displaying the span gas signal as confirmation.

The span gas signal corresponds with an output signal of approx. -10 %LEL of the respectively set gas category, or, to be more precise: a gas concentration of -0.44 Vol.-% for methane (100 %LEL = 4.4 Vol.-% methane), -0.17 Vol.-% for propane (100 %LEL = 1.7 Vol.-% propane), -0.23 Vol.-% for ethylene (100 %LEL = 2.3 Vol.-% ethylene).

This notice is correspondingly valid for all other signal readings in %LEL.

Manual Span Calibration of the Output Signal ¹⁾

The span calibration of the gas sensor is only possible under the following conditions:

- The last zero calibration of the device was less than one hour ago.
- The span gas concentration is sufficiently high to effect a display on the device of at least approx. 20 %LEL.

- Deactivate alarm activation of the central device.

- 1 Use calibration adapter to expose gas sensor to test gas and wait until measurement value stabilises.
 - 2 Place the magnetic pin onto the sensor surface area marked by the " ↑S " icon and hold it there (within the black frame) for at least five seconds. The output signal of the gas sensor changes to the display of the span gas signal (display change to approx. -10 %LEL).
 - 3 Remove the magnetic pin. The output signal of the gas sensor changes back to the normal display. The device is now set to span calibration routine. While in this routine, the display will decrease resp. increase, depending on whether the magnetic pin is placed on either of the areas marked by the " ↓0 " or " ↑S " icons.
 - 4 Adjust the output signal by placing the magnetic pin on one of the areas marked by the " ↓0 " or " ↑S " icons.
 - 5 Remove the magnetic pin. The device terminates the span calibration routine after 30 seconds without further changes being made. As confirmation of the successful calibration, the output signal changes back to the span gas signal (display change by approx. -10 %LEL). This signal is indicated for the same period of time as when starting the span calibration routine.
 - 6 Stop the exposure to gas, then wait for the display to fall back to zero.
- Reactivate alarm activation of the central device.

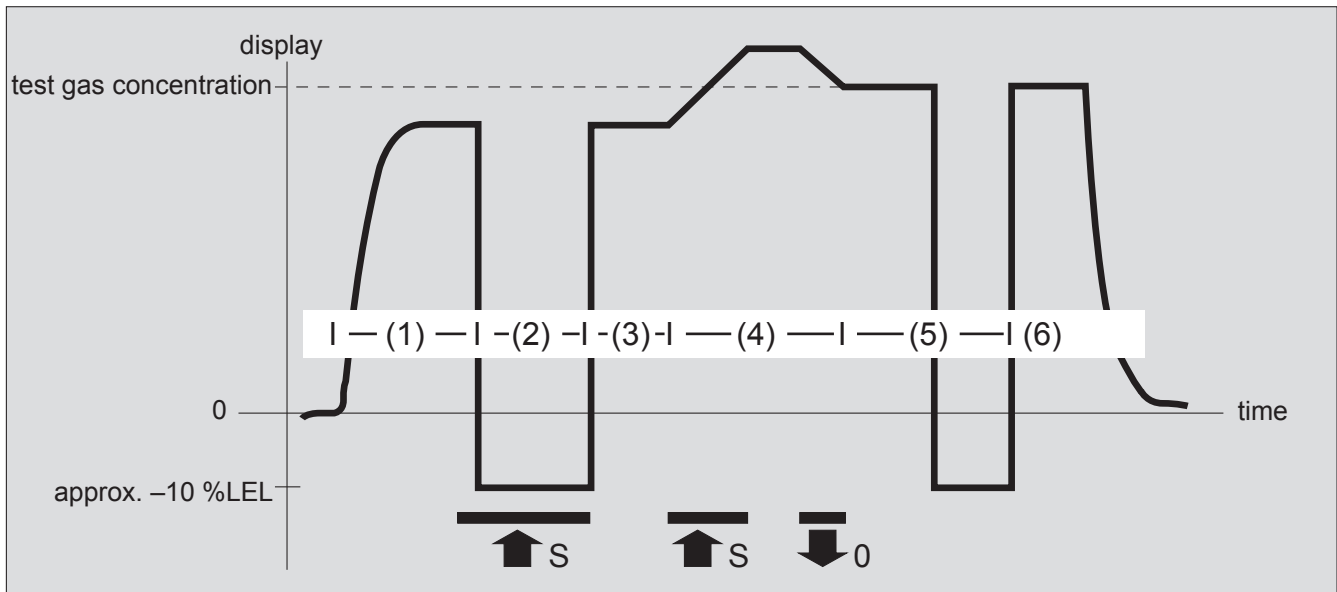
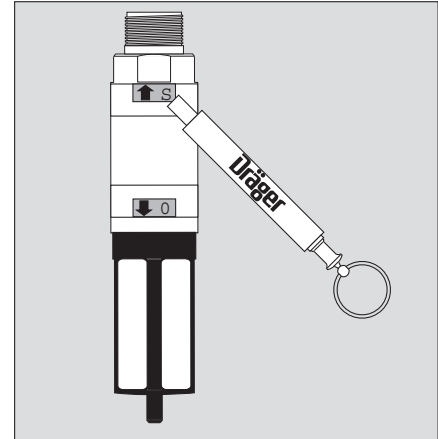

1) The values in %LEL mentioned in this section are only valid for gas warning systems that are calibrated for the measured gases methane, propane or ethylene. The actual LEL values [%] may deviate from the mentioned LEL values [%] on gas warning systems which have not yet been calibrated or which were calibrated with a substitute gas and a calibration factor.

NOTICE

The calibration is automatically terminated and new calibration parameters are not saved if the gas concentration measured by the gas sensor changes during the calibration procedure (e.g. because the calibration gas cylinder fell empty during the calibration procedure). In this case, the gas sensor returns to normal operation without displaying the span gas signal as confirmation.

A reduction of sensitivity to below 40 % of the factory-preset values within an hour after commissioning the sensor will cause the display to invert (see "Inverting the Output Signal" on page 20).

Substitute Gas Calibration**⚠ WARNING**

Due to the design of the gas sensor, the output signal of the gas sensor is limited to 45 %...55 % of the supply voltage. If the gas concentrations increase further after the maximum sensor output signal has been reached, this does not lead to an increase of the values displayed on the central device. In case of substances with particularly low calibration factors and/or manual configuration of a high span calibration factor at the sensor, this may already happen at concentrations below 100 %LEL. For substitute gas calibrations, correct triggering of the alarm should therefore be checked with a test gas concentration corresponding to the alarm threshold. If necessary, the measuring range which can be represented can be increased as required by a reduction of the sensor output signal (see "Manual Span Calibration of the Output Signal" on page 18) and subsequent calibration at the central device.

The infrared gas sensor DrägerSensor IR can also be used to measure other gases and vapours. The following table contains relevant information (see also "Calibration" on page 12).

Measured gas ¹⁾	CAS-No.	Measuring range ¹⁾ [%LEL]	Gas Category Sub- stitute Gas	Calibration factor ^{2) 3)}	Response time t _{0...50}
acetone	67-64-1	0 to 100	ethylene	0.7	≤ 24 s
i-butane	75-28-5	0 to 100	propane	1.6	≤ 21 s
n-butane	106-97-8	0 to 100	propane	1.2	≤ 23 s
ethanol	64-17-5	0 to 100 ⁴⁾	propane	0.9	≤ 21 s
ethyl acetate	141-78-6	0 to 100	ethylene	0.4	≤ 35 s
ethyl acetate	141-78-6	0 to 100 ⁴⁾	propane	1.4	≤ 35 s
n-hexane	110-54-3	0 to 100	propane	1.8	≤ 32 s
methanol	67-56-1	0 to 100 ⁴⁾	ethylene	0.2	≤ 21 s
n-nonane	111-84-2	0 to 100	propane	1.9	≤ 89 s
n-Octane	111-65-9	0 to 100	propane	1.8	≤ 67 s
n-pentane	109-66-0	0 to 100	propane	1.5	≤ 28 s
i-propyl alcohol	67-63-0	0 to 100	propane	1.3	≤ 24 s
propene (propylene)	115-07-1	0 to 100	ethylene	0.4	≤ 19 s
toluene	108-88-3	0 to 100	ethylene	0.6	≤ 49 s

1) The measuring function for the explosion protection according to EN 60079-29-1 is proven, see EC-Type Examination certificate BVS 05 ATEX E 143X and associated additions as well as DMT 02 ATEX G 002X and associated additions.

2) The LEL values were used according to IEC 60079-20-1. Other LEL values may apply for the device settings at the location of use.

3) Typical tolerance: ±5 %.

4) When the following substances are measured at concentrations above 70 % LEL, the deviations of the measured values exceed the permitted deviations in accordance with EN 60079-29-1.

Inverting the Output Signal¹⁾



The DrägerSensor IR gas sensor has been factory-preset and configured to ensure that the output signal (medium potential of emulated half bridge) rises along with the gas concentration (within the output signal specification). There are central devices which expect the output signal to drop as gas concentration rises. To have the DrägerSensor IR operate with this kind of central device, the output signal must be inverted.

The inversion can be carried out using the span calibration. This is only possible under the following conditions:



- The device was less was started up less than an hour ago.
- The last zero calibration of the device was less than one hour ago.
- The span gas concentration is sufficiently high to effect a display on the device of at least approx. 20 %LEL.

The following description presupposes that the gas sensor is connected to a central device which expects a decreasing output signal as the gas concentration rises and is capable of displaying negative values.

- Deactivate alarm activation of the central device.

- 1 Expose the gas sensor to test gas via calibration adapter. Corresponding to the factory-preset configuration of the output signal, the central device displays a negative gas concentration. Allow the measurement value to stabilise.
- 2 Place the magnetic pin onto the sensor surface area marked by the "  S " icon and hold it there for at least five seconds. The output signal of the gas sensor changes to the display of the span gas signal (display change to approx. +10 %LEL).
- 3 Remove the magnetic pin. The output signal of the gas sensor changes back to the negative display of the gas concentration. The device is now set to span calibration routine.
- 4 Put the magnetic pin the area marked by the "  0 " icon to change the display towards zero. As soon as the negative display drops below 40 % of the factory-preset value, the output signal is automatically inverted; in the process, the display of the central device switches to a positive value.

- The inverting process also adapts (reverses) the direction-effect of the magnet contacts at the central device.

So: After inverting, remove the magnetic pin from the area marked with the "  0 " icon, then increase the display by putting the magnetic pin on the area marked with the "  S " icon until the display matches the test gas concentration.

- 5 Remove the magnetic pin. The device terminates the span calibration routine after 30 seconds without further settings being carried out. To confirm the successful calibration, the output signal changes back to the span gas signal (now, after successful inverting, corresponding negative value of approx. –10 %LEL). This signal is indicated for the same period of time as when starting the span calibration routine.
 - 6 Terminate exposure to gas.
- Reactivate alarm activation of the central device.

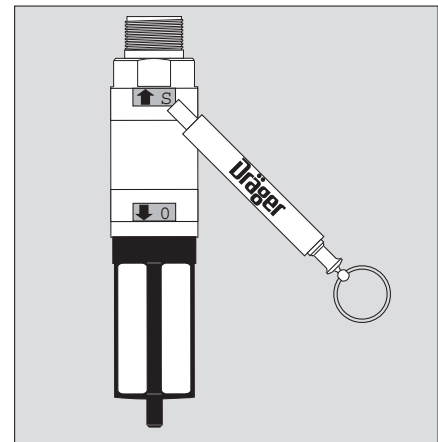

1) The values in %LEL mentioned in this section are only valid for gas warning systems that are calibrated for the measured gases methane, propane or ethylene. The actual LEL values [%] may deviate from the mentioned LEL values [%] on gas warning systems which have not yet been calibrated or which were calibrated with a substitute gas and a calibration factor.

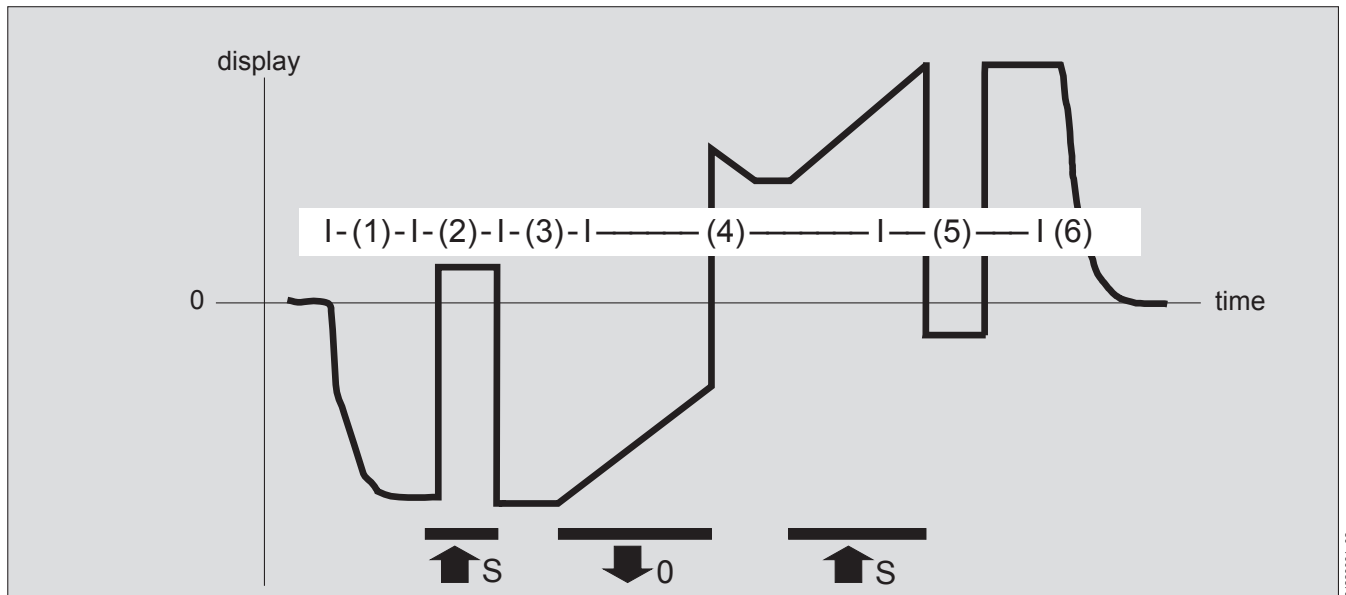

Checking the Signal transmission, Checking the Alarm Trigger and Displaying¹⁾ the Gas Category

The gas sensor can create an output signal of 80 % of the full scale value, even without exposure to test gas. This 80% signal can be used to

- check the signal transmission of the central device,
- match central device and sensor signal,
- check the alarm triggering of the gas warning system.

After issuing the 80% signal, the gas category set at the gas sensor is displayed before the gas sensor returns to normal operation.

- De-energising the alarm activation of the central device (not during alarm testing).
- Expose the gas sensor to nitrogen, synthetic air, resp. fresh air via calibration adapter and wait until measurement value stabilises.
- Place the magnetic pin onto the sensor surface area marked by the " ↓0 " icon and hold it there (within the black frame) for at least five seconds. After five seconds, the output signal of the gas sensor changes to the display of the span gas signal (display change by approx. –10 %LEL) for as long as the magnetic pin is held against it. At the same time, an automatic zero setting of the optical measuring unit is carried out

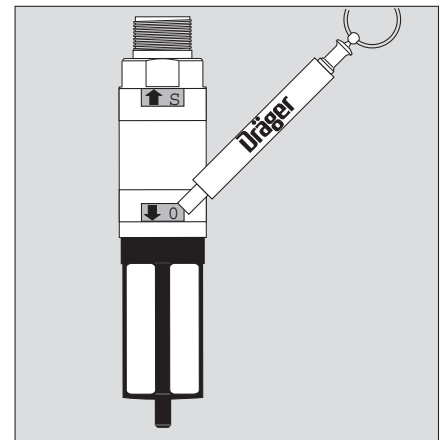

1) The values in %LEL mentioned in this section are only valid for gas warning systems that are calibrated for the measured gases methane, propane or ethylene. The actual LEL values [%] may deviate from the mentioned LEL values [%] on gas warning systems which have not yet been calibrated or which were calibrated with a substitute gas and a calibration factor.

- Remove the magnetic pin. After 30 seconds, the device exits the automatic zero-setting routine. As confirmation of the automatic zero-setting, the output signal changes back to the span gas signal (display change by approx. -10 %LEL). This signal is indicated for the same period of time as when starting the automatic zero-setting routine.
- Check the display of the central device: set point 0 %LEL.
- If required, set the zero point display (zero) to 0 %LEL at the central device. While doing so, observe the information in the operating manual of the central device pertaining to this subject.
- Place the magnetic pin onto the sensor surface area marked by the " ↑S " icon (within the black frame) and hold it there. After ten seconds, the output signal of the gas sensor changes to the 80% signal for as long as the magnetic pin is held against it.
- Check the display of the central device: set point 80 %LEL.
- If required, adjust the span at the central device until the central device displays 80 %LEL. While doing so, observe the information in the operating manual of the central device pertaining to this subject.
- Remove the magnetic pin. The gas sensor changes to an output signal which displays the currently set gas category according to the following table:

Gas category	Display [%LEL]
methane	20
propane	40
ethylene	60

- This signal is maintained for 30 seconds. The gas sensor will then switch back to normal operation.
- The central device display is now synchronised with the output signal of the gas sensor.
- Reactivate alarm activation of the central device.

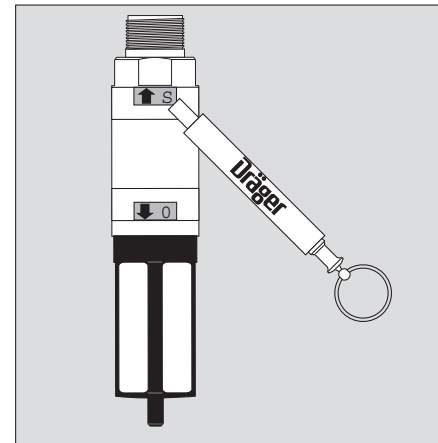

01623143_01_01.jpg

NOTICE

Using the 80% signal to match central device and sensor signal without test gas is no replacement for the functional check or the span calibration of the gas warning system.

Changing the Gas Category¹⁾

The gas sensor supports the linearized and temperature compensated display of a wide spectrum of gases and vapours. Depending on the measured gas, you can select one of the three gas categories "methane", "propane" or "ethylene" stored in the software. A table which allocates a series of tested gases and vapours is available in the table "Substitute Gas Calibration" on page 19.

Changing the gas category is only possible under the following conditions:

- The device was less was started up less than an hour ago.
- The last zero calibration of the gas sensor was less than an hour ago.
- The gas concentration measured by the device is below 10 %LEL (expose to zero gas if necessary).

To change the gas category of gas sensors which have already been started up, interrupt the power supply for a short period of time, wait for the running-in period of one minute to expire, and then carry out an automatic zerosetting (see section "Automatic Zerosetting" on page 15).

Then:

- Deactivate alarm activation of the central device.
- Place the magnetic pin onto the sensor surface area marked by the "  " icon (within the black frame) and hold it there. After ten seconds, the output signal of the gas sensor changes to the 80% signal for as long as the magnetic pin is held against it.
- Remove the magnetic pin. The gas sensor changes to an output signal which displays the currently set gas category according to the following table:

Gas category	Display [%LEL]
methane	20
propane	40
ethylene	60

This signal is maintained for 30 seconds. Within this period of time, the magnetic pin can be placed upon the area marked by the "  " icon to select the next gas listed in the table. In the process, the output signal of the gas sensor changes to the value which corresponds with the newly selected gas category value.

The gas sensor returns to normal operation if no further entry with the magnetic pin is performed for 30 seconds.

- Check span calibration (see page 17).
- Reactivate alarm activation of the central device.

1) The values in %LEL mentioned in this section are only valid for gas warning systems that are calibrated for the measured gases methane, propane or ethylene. The actual LEL values [%] may deviate from the mentioned LEL values [%] on gas warning systems which have not yet been calibrated or which were calibrated with a substitute gas and a calibration factor.

Maintenance

Regular intervals

are to be determined for the following tasks by the persons responsible for the gas warning system while taking local regulations into account:

- Visual inspection to look for damage and contamination.
Special attention is required for gas entrance to the sensor. Anything that blocks the gas entrance to the sensor, e.g. dirt, ice, precipitation, etc., can prolong the response times or even completely disable the gas sensor.
Recommended inspection interval: 3 months.
- Visual inspection of the splash guard. If required, dismount the calibration adapter, dirt deflector and/or gas exposure / process adapter. Clean or replace dirty or damaged splash guard.
- Visual inspection of the dirt deflector. Clean or replace dirty or damaged dirt deflector.
- Visual inspection of gas exposure / process adapter. Clean or replace dirty or damaged gas exposure / process adapter.
- Check signal transmission and adjust if required (see "Checking the signal transmission, checking the alarm trigger and displaying the gas category" on page 21).
- Check the calibration of the gas warning system (see "Calibration" on page 12). Recommended calibration interval: 6 months.
- Observe standard DIN EN 60079-29-2 (provided binding).

Extending the maintenance intervals is possible if local conditions are taken into account, and if the recommended maintenance intervals require cleaning, maintenance or setup work. However, we do not recommend maintenance intervals that are longer than 12 months.

Yearly

Inspection by competent personnel. The inspection intervals are to be individually determined with regard to safety regulations, process control conditions and device-related requirements. We strongly recommend that a service contract be signed with DrägerService[®] ¹⁾ to have them handle repairs and maintenance.

1) DrägerService[®] is a registered trademark of Dräger.

Faults, Cause and Remedy

Fault	Cause	Remedy
no output signal	gas sensor is not powered up	Check power supply and polarity.
	gas sensor defective	Have Dräger check the gas sensor.
instable output signal	insufficient electrical power at the sensor	Provide 1 W electrical power at the sensor. Increase supply voltage of central device.
	resistance of supply line too high	Reduce length of line, increase cable diameters, check contacts.
sensor output signal and central device display do not match	central device and gas sensor are not synchronised	Synchronise central device and gas sensor, see "Checking the signal transmission, checking the alarm trigger and displaying the gas category" on page 21.
output signal close to negative supply voltage	supply voltage too low resp. too high	Check supply voltage, see "Electrical Installation" on page 8. Restart by interrupting the power supply for a moment.
	ambient temperature too high resp. too low	Operate gas sensor within the specified temperature range, see "Technical Data" on page 26.
	zero point of the sensor not synchronised.	Synchronise the zero point of the sensor, see "Automatic Zero-setting" on page 15.
	gas sensor defective	Have Dräger check the gas sensor.
output signal oscillates with 2 Hz (in constant voltage mode)	unequal lead resistances	Synchronise lead resistances.
		If possible: operate gas sensor in current mode.
high linearity error	wrong gas category set	Change the gas category, see "Changing the Gas Category" on page 23.
possible calibration range at central device exhausted	calibration range at central device too small	Calibrate system at gas sensor.
no output signal	gas sensor is not powered up	Check power supply and polarity.
	gas sensor defective	Have Dräger check the gas sensor.
high gas concentration cannot be represented at the central device	sensor output signal at maximum level	Reduce the sensor output signal, see "Manual Span Calibration of the Output Signal" on page 18; then perform a span calibration at the central device and check the alarm trigger function.

Technical Data

General Details

functional principle	compensated infrared absorption
standard operating range	0 – 100 %LEL
standard sensitivity	0.576 mV/%LEL at 300 mA
standard gas categories	methane, propane, ethylene
output signal	45 to 55 % of the supply voltage (half bridge emulation)
power supply	200 to 400 mA DC (constant current mode) 2.5 to 5 V DC (constant voltage mode)
switch-on current (3 ms)	≤1.25 A
power consumption	≤1 W
connecting thread	M25x1.5 or 3/4" NPT
material	stainless steel SS 316
weight	approx. 550 g
dimensions	see "Dimensions" on page 30
Terminal box of complete set:	
Cable gland	M20x1.5 brass, nickel-plated for cable with Ø 7-12 mm (order no. 68 11 165 and 68 11 265) or 3/4" NPT thread (order no. 68 11 185).
Permissible conductor cross-sections:	1.0 to 2.5 mm ² (Order No. 68 11 165) or 0.5 to 4.0 mm ² (Order No. 68 11 265) or 0.2 to 4.0 mm ² (Order No. 68 11 185)
environmental operating ranges	–40 to 65 °C 700 to 1300 hPa 0 to 100 % rel. hum.
environmental storage ranges	–40 to 70 °C 700 to 1300 hPa 0 to 100 % rel. hum., non-condensing
IP rating	IP 66, IP 67 ¹⁾ , NEMA 4X&7
CE marking	devices and protection systems for intended use in potentially explosive atmospheres (Directive 2014/34/EU); electromagnetic compatibility (Directive 2014/30/EU)

1) Blockage of the gas entrance to the gas sensor due to dirt or precipitation can prolong the response times or even completely disable the gas sensor.

Measuring Technique Characteristics (Typical Values)

digital resolution of measurement values	±0,5 %LEL		
repeatability	≤ ±2 %LEL		
linearity error	≤ ±5 %LEL		
temperature influence, –40 to 65 °C			
zero point	≤ ±3 %LEL		
span (rel. change of display at 50 %LEL)	≤ ±0,06 % / °C		
humidity influence, 0 to 100 % rel. hum. at 40 °C			
zero point	≤ ±3 %LEL		
span	≤ ±5 %LEL		
pressure influence, 700 to 1300 hPa			
zero point	≤ ±2 %LEL		
span (rel. change of display at 50 %LEL)	≤ ±0.17 % / hPa		
time to start up	approx. 60 seconds		
warm-up phase	approx. 2 hours		
Stabilisation time (when feeding test gas)	≥ 45 seconds ¹⁾		
Update rate of the output for measuring value outputs	1 second		
Measurement value setting times ^{2) 3) 4)}	Methane	Propane	Ethene (Ethylene)
without splash guard $t_{0...50}$	≤ 18 seconds	≤ 18 seconds	≤ 14 seconds
without splash guard $t_{0...90}$	≤ 30 seconds	≤ 39 seconds	≤ 35 seconds
with splash guard and calibration adapter $t_{0...50}$	≤ 20 seconds	≤ 24 seconds	≤ 20 seconds
with splash guard and calibration adapter $t_{0...90}$	≤ 35 seconds	≤ 60 seconds	≤ 59 seconds
with splash guard and mud flap $t_{0...50}$	≤ 22 seconds	≤ 26 seconds	≤ 31 seconds
with splash guard and mud flap $t_{0...90}$	≤ 56 seconds	≤ 70 seconds	≤ 79 seconds
with splash guard and process adapter (1.0 to 1.5 l/min.) $t_{0...50}$	≤ 20 seconds	≤ 22 seconds	≤ 20 seconds
with splash guard and process adapter (1.0 to 1.5 l/min.) $t_{0...90}$	≤ 46 seconds	≤ 51 seconds	≤ 54 seconds
Expected service life	>10 years		

1) The stabilisation time can increase depending on the flow rate and the hose length.

2) The response times have been determined by flow when using the process adapter accessory. For all other cases, the response times have been determined by diffusion.

3) The setting time for the entire system is determined using the setting times for all parts of the entire gas warning system.

4) The response times may vary with other approved substances. Depending on the accessories used longer response times are possible.

Cross Sensitivities

The gas sensor measures the concentration of hydrocarbons. Factory-preset calibration parameters are available for methane, propane and ethylene gases. However, other hydrocarbons can also be measured. The following text has examples of typical display values for some types of hydrocarbon, with the gas sensor calibrated in the respectively stated gas category.

name of substance ¹⁾	CAS-No.	LEL according to IEC [Vol.%]	gas category	display of 50 %LEL ^{2) 3)} in %LEL of target gas category
acetone	67-64-1	2.5	ethylene	75
benzene	71-43-2	1.2	ethylene	58
1.3-butadiene	106-99-0	1.4	ethylene	47
i-butane	75-28-5	1.3	propane	32
n-butane	106-97-8	1.4	propane	42
n-butanol	71-36-3	1.4	propane	30
n-butene	106-98-9	1.6	propane	48
n-butyl acetate	123-86-4	1.3	propane	30
n-butyl acrylate	141-32-2	1.2	propane	31
chlorobenzene	108-28-5	1.3	ethylene	25
cyclopentane	287-92-3	1.4	propane	46
diethyl ether	115-10-6	2.7	propane	64
1.4-dioxane	123-91-1	1.4	propane	21
ethanol	64-17-5	3.1	propane	56
ethylene	74-85-1	2.3	ethylene	50
ethyl acetate	141-78-6	2.0	propane	36
ethyl acetate	141-78-6	2.0	ethylene	>100
ethylbenzene	100-41-4	0.8	propane	26
n-hexane	110-54-3	1.0	propane	28
methane	74-82-8	4.4	methane	50
methanol	67-56-1	6.0	propane	>100
methanol	67-56-1	6.0	ethylene	>100
1-methoxy-2-propanol	107-98-2	1.6	propane	41
methyl-i-butylcetone	108-10-1	1.2	propane	26
methyl ethyl ketone (butanone)	78-93-3	1.5	propane	31
methyl methacrylate	80-62-6	1.7	propane	38
n-nonane	111-84-2	0.7	propane	28
n-octane	111-65-9	0.8	propane	30
i-pentane	78-78-4	1.3	propane	38
n-pentane	109-66-0	1.1	propane	35
propane	74-98-6	1.7	propane	50
i-propyl alcohol	67-63-0	2.0	propane	37
propene (propylene)	115-07-1	2.0	propane	33
propene (propylene)	115-07-1	2.0	ethylene	>100
propylene oxide	75-56-9	1.9	propane	54
styrene	100-42-5	1.0	ethylene	44
tetrahydrofuran	109-99-9	1.5	propane	44
toluene	108-88-3	1.0	ethylene	85
o-xylene	95-47-6	1.0	ethylene	68

1) Substances with a verified measuring function for explosion protection are listed in the EC-Type Examination certificate BVS 05 ATEX E 143X and the associated additions.

2) The LEL values were used according to IEC 60079-20-1. Other LEL values may apply for the device settings at the location of use.

3) Typical tolerance: $\pm 5\%$.

Dimensions

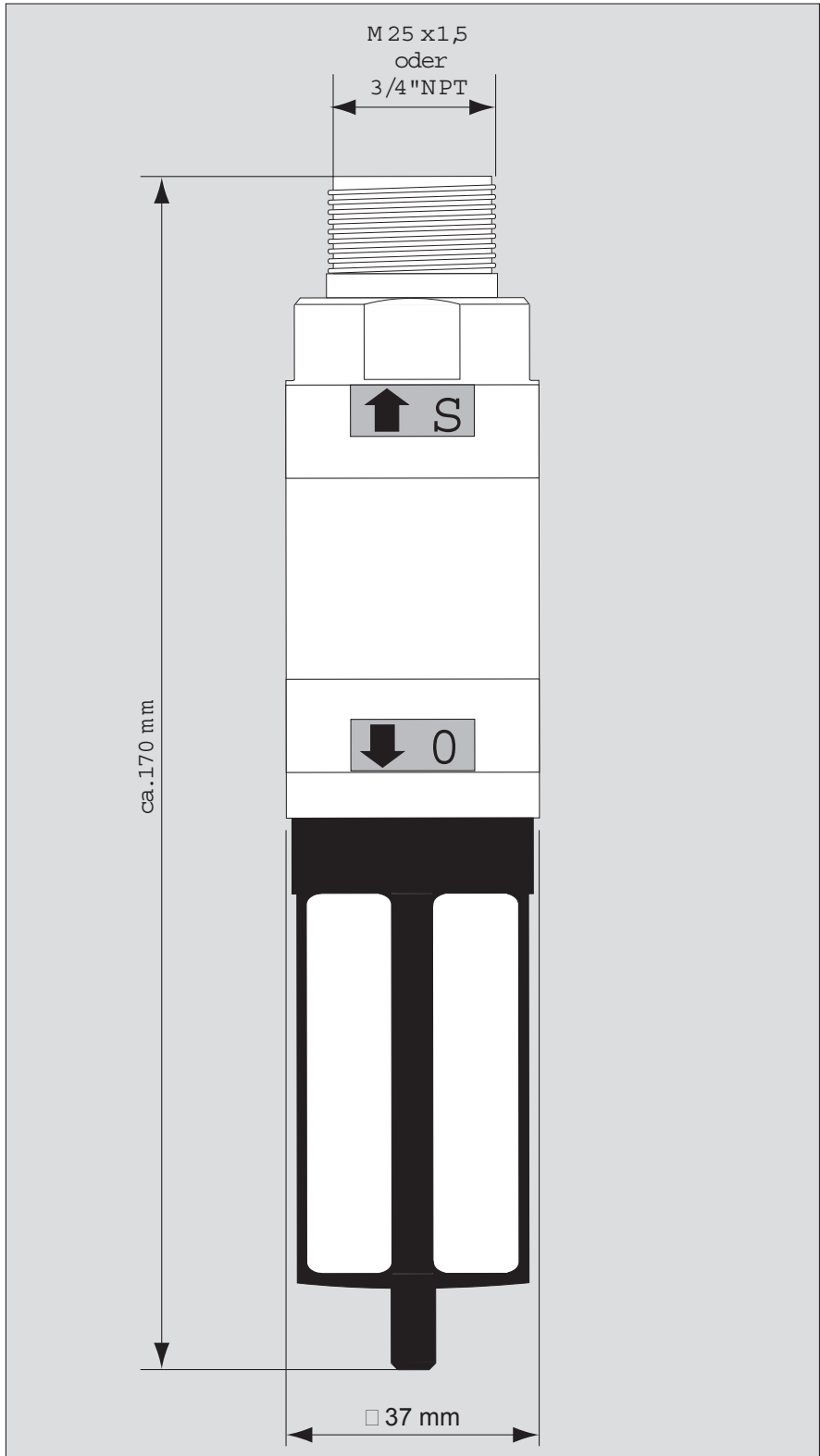

Description of Design

The DrägerSensor IR infrared gas sensor is a gas transmitter designed to determine the concentration of gases and vapours in the ambient air. The principle of measurement is based on the concentration-dependent absorption of infrared radiation in measured gases.

The monitored ambient air diffuses through sintered material into the flameproof housing of a measuring cuvette. The broadband light emitted by the radiator passes through the gas in the cuvette and is reflected by the cuvette walls from where it is directed towards the inlet window of a dual element detector. One channel of the detector measures the gas-dependent light transmission of the cuvette (measuring channel), the other channel is used as reference. The ratio between measuring and reference signal is used to determine the gas concentration in the cuvette. The cuvette is heated to avoid condensation of the atmosphere's moisture content.

Internal electronics and software are used to calculate the concentration. As an output signal, the gas sensor emulates the half bridge of a catalytic Ex sensor.

Due to its robust design and the measuring method, the gas sensor has long maintenance and calibration intervals (see "Maintenance" on page 24). A gas sensitivity drift is very unlikely due to the infrared-optical principle of measurement and in addition, the zero point stability is enhanced by an automatic tracking system.

Order List

Designation and description	Order No.
DrägerSensor IR infrared gas sensor	
DrägerSensor IR ^{1) 5)} connecting thread 3/4" NPT, type IDS 0002	68 11 110
DrägerSensor IR compl. set d ^{2) 5)} connecting thread 3/4" NPT, type ISH 0010	68 11 185
DrägerSensor IR connecting thread 3/4" NPT, variant of combination with Polytron 5310, Polytron 8310 and Polytron FX CSA, type IDS 0002	68 11 901
DrägerSensor IR connecting thread 3/4" NPT, variant of combination with Polytron FX, type IDS 0002	68 11 111
DrägerSensor IR connecting thread 3/4" NPT, variant of combination with Polytron 2 XP Ex CSA, type IDS 0002	68 11 900
DrägerSensor IR connecting thread 3/4" NPT, variant of combination with Polytron 2 XP Ex, type IDS 0002	68 11 300
DrägerSensor IR ^{1) 5)} connecting thread M 25 x 1.5, type IDS 0012	68 11 100
DrägerSensor IR compl. set e ^{3) 5)} connecting thread M 25 x 1.5, type ISH 0001	68 11 165
DrägerSensor IR compl. set e2 ^{4) 5)} connecting thread M 25 x 1.5, type ISH 0002	68 11 265
Accessories/Spare parts ⁶⁾	
splash guard	68 10 796
calibration adapter	68 10 859
gas exposure / process adapter	68 11 330
dirt deflector	68 11 135
assembly set e	68 11 427
assembly set d	68 11 426
pipe connection set (duct mount)	68 10 995
magnetic rod	45 44 101
terminal box in Ex d design (explosion proof, 3/4" NPT, Ø10.0 cm)	68 11 161
terminal box in Ex e design (increased safety, M25, 11,0 x 7.5 x 5.5 cm)	68 11 299
terminal box in Ex e design (increased safety, M25, 12.0 x 12.0 x 7.4 cm)	68 11 159
cable gland set M20	68 11 323
XP adapter cable DSIR	68 11 107
Instructions for Use	90 23 843
Installation Instructions	90 23 867

1) Splash guard and calibration adapter belong to the scope of delivery.

2) The complete set includes the terminal box (68 11 161), the splash guard as well as the calibration adapter, already preassembled.

3) The complete set includes the terminal box (68 11 165), the splash guard as well as the calibration adapter, already preassembled.

4) The complete set includes the terminal box (68 11 265), the splash guard as well as the calibration adapter, already preassembled.

5) The measuring function for the explosion protection according to EN 60079-29-1 is proven, see EC-Type Examination certificate BVS 05 ATEX E 143X and associated additions.

6) Not included in the EU type examination certificate BVS 05 ATEX E 143 X.

ATEX - Approval



Translation

(1) EC-Type Examination Certificate

- (2) - Directive 94/9/EC -
Equipment and protective systems intended for use
in potentially explosive atmospheres

- (3) **BVS 05 ATEX E 143 X**

- (4) **Equipment:** Gas detection sensors type IDS 0011 resp. type IDS 0012 resp.
type IDS 0001 resp. type IDS 0002 and
Gas detection heads type ITR 0001 resp. type ITR 0002 resp.
type ITR 0010 resp. type ISH 0001 resp. type ISH 0002 resp.
type ISH 0010

- (5) **Manufacturer:** Dräger Safety AG & Co. KGaA

- (6) **Address:** 23560 Lübeck

- (7) The design and construction of this equipment and any acceptable variation thereto are specified in the schedule to this type examination certificate.

- (8) The certification body of EXAM BBG Prüf- und Zertifizier GmbH, notified body no. 0158 in accordance with Article 9 of the directive 94/9/EC of the European Parliament and the Council of 23 March 1994, certifies that this equipment has been found to comply with the Essential Health and Safety Requirements relating to the design and construction of equipment and protective systems intended for use in potentially explosive atmospheres, given in Annex II to the Directive.

The examination and test results are recorded in the test and assessment report BVS PP 05.2107 EG.

- (9) The Essential Health and Safety Requirements are assured by compliance with:

EN 50014:1997 + A1 – A2	General Requirements
EN 50018:2000 +A1	Flameproof enclosure
EN 50019:2000	Increased safety
EN 60079-7:2003	Increased safety
EN 50281-1-1:1998	Dust explosion protection

- (10) If the sign „X“ is placed after the certificate number, it indicates that the equipment is subject to special conditions for safe use specified in the schedule to this certificate.

- (11) This EC-Type Examination certificate relates only to the design, examination and tests of the specified equipment in accordance to Directive 94/9/EC.
Further requirements of the Directive apply to the manufacturing process and supply of this equipment. These are not covered by this certificate.

- (12) The marking of the equipment shall include the following:

 **II 2G EEx d IIC T6 resp. II 2G EEx de IIC T6**
II 2D IP 6X T 80 °C

EXAM BBG Prüf- und Zertifizier GmbH

Bochum, dated 26. September 2005

Signed: Jockers

Signed: Eickhoff

Certification body

Special services unit

Page 1 of 4 to BVS 05 ATEX E 143 X

This certificate may only be reproduced in its entirety and without change.

Dinnendahlstraße 9 44809 Bochum Telefon-Phone 0234/3696-105 Telefax-Fax 0234/3696-110

(13)

Appendix to

(14)

EC-Type Examination Certificate

BVS 05 ATEX E 143 X

(15) 15.1 Subject and Type

Gas detection sensors type IDS 0001 resp. IDS 0011 resp. type IDS 0002 resp. type IDS 0012 and Gas detection heads type ITR 0001 resp. type ITR 0002 resp. type ITR 0010 resp. type ISH 0001 resp. type ISH 0002 resp. type ISH 0010

Gas detection sensors type IDS 0011 resp. type IDS 0012 providing M25 thread connection for attachment to an enclosure increased safety „e“

Gas detection sensors type IDS 0001 resp. type IDS 0002 providing NPT ¼“ thread connection for attachment to a flameproof enclosure „d“

Gas detection heads type ITR 0001 resp. type ISH 0001 with type of protection increased safety „e“ by use of enclosure type 07-5185-1100/7555 according EC-type Examination Certificate PTB 01 ATEX 1014 U (certified per PTB 01 ATEX 1104 and IBEXU00ATEX1081 as a complete terminal box).

Gas detection heads type ITR 0002 resp. type ISH 0002 with type of protection increased safety „e“ by use of enclosure type PL 612 according EC-Type Examination Certificate BAS 01 ATEX 2107 X.

Gas detection heads type ITR 0010 resp. type ISH 0010 with type of protection flameproof enclosure „d“ by use of enclosure type SL 26.1N according EC-Type Examination Certificate CESI 03 ATEX 059 U resp. CESI 02 ATEX 091.

15.2 Description

The sensors type IDS 0001 resp. type IDS 0011 resp. type IDS 0002 resp. type IDS 0012, manufactured using type of protection flameproof enclosures „d“, provide measurement of combustible gases and vapors under atmospheric conditions. The sensors are suitable for use in an ambient temperature range of -40 °C to +65 °C.

The non-intrinsically safe power supply of the sensors enters the enclosure via a resin bushing. The sensor type IDS 0011 resp. type IDS 0012 may be attached to an enclosure of type of protection increased safety „e“ that is certified for this purpose. The sensor type IDS 0001 resp. IDS 0002 is dedicated for the attachment to a flameproof enclosure „d“. The mechanical strength of the attachment to the flameproof enclosure as well as the explosion relevant and constructional assessment of the connection thread shall be made in conjunction with the certification of the electrical apparatus to which the sensor is attached.

The gas detection heads type ITR 0001 resp. type ISH 0001 and type ITR 0002 resp. type ISH 0002 consist of a gas detection sensor type IDS 0011 resp. type IDS 0012 and an attached terminal box with type of protection increased safety „e“, fitted with terminals that are certified for this purpose. The gas detection heads type ITR 0001 resp. type ISH 0001 and type ITR 0002 resp. type ISH 0002 provide measurement of combustible gases and vapors under atmospheric conditions and are suitable for use in an ambient temperature range of -40 °C to +65 °C.

The gas detection heads type ITR 0010 resp. type ISH 0010 consist of a gas detection sensor type IDS 0001 resp. type IDS 0002 and an attached terminal box, comprising terminals with type of protection flameproof enclosures „d“. The gas detection heads type ITR 0010 resp. type ISH 0010 provide measurement of combustible gases and vapors under atmospheric conditions and are suitable for use in an ambient temperature range of -40 °C to +60 °C.

15.3 Parameters

15.3.1 Supply of the gas detection sensors and gas detection heads

Voltage	up to	30 V
Power	up to	2 W

15.3.2 Temperatures

Ambient Temperature Range for
Gas detection sensors type IDS 0001 resp. type IDS 0011 resp. type IDS 0002
resp. type IDS 0012 and
Gas detection heads type ITR 0001 resp. type ISH 0001 resp. type ITR 0002 resp. type ITR 0002
-40 °C to +65 °C

Ambient Temperature Range for
Gas detection heads type ITR 0010 resp. type ISH 0010 -40 °C to +60 °C

Gas detection sensors type IDS 0001 resp. type IDS 0011 resp. type IDS 0002 resp. type IDS 0012
Maximum permissible Temperature at resin at maximum
permissible power and ambient temperature 75 °C
Maximum permissible Temperature of wires at maximum
permissible power and ambient temperature 70 °C

(16) Test and assessment report

BVS PP 05.2107 EG, dated 26.09.2005

(17) Special conditions for safe use

The gas detection sensors type IDS 0001 resp. type IDS 0011 resp. type IDS 0002 resp. type IDS 0012 and the gas detection heads type ITR 0001 resp. type ISH 0001 and type ITR 0002 resp. ISH 0002 are suitable for use in an ambient temperature range of -40 °C to +65 °C.

The gas detection heads type ITR 0010 resp. type ISH 0010 are suitable for use in an ambient temperature range of -40 °C to +60 °C.

The gas detection sensor type IDS 0001 resp. IDS 0002 (NPT-thread) is suitable for the attachment to an enclosure with type of protection flameproof enclosures „d“. The free internal volume is limited to 2 liters and the maximum reference pressure may not exceed 20 bar. The mechanical strength of the attachment to the flameproof enclosure as well as the explosion relevant and constructional assessment of the connection thread shall be made in conjunction with the certification of the electrical apparatus to which the sensor is attached.

The gas detection sensor type IDS 0011 resp. type IDS 0012 (metric thread) is suitable for the attachment to an enclosure with type of protection increased safety „e“. The mechanical strength and the ingress protection IP 6X of the attachment shall be ensured by the certification of the electrical apparatus to which the sensor will be attached. After attachment of the sensor to an enclosure with type of protection increased safety „e“, the clearance and creepage distances must comply with clause 4.3 (Table 1) of

Page 3 of 4 to BVS 05 ATEX E 143 X

This certificate may only be reproduced in its entirety and without change.
Dinnendahlstraße 9 44809 Bochum Telefon-Phone 0234/3696-105 Telefax-Fax 0234/3696-110

EN 50019 resp. clauses 4.4 and 4.5 of EN 60079-7. The wires of the sensors shall be routed and connected according clauses 4.2, 4.5.1 and 4.8 of EN 50019 resp. clauses 4.3, 4.61 and 4.9 of EN 50079-7 mechanically protected and by observation of the temperature rating of the wires.

The sensors shall be appropriately screwed into the enclosure wall and secured against self-loosening. After attachment, the sensor's enclosure shall be connected to the equipotential bonding of the terminal box in an electrostatic manner (resistance $< 10^6$ Ohms). If equipotential bonding is necessary, it shall be ensured by the attachment.

The measurement function for explosion protection in accordance with EN 61779-1 and EN 61779-4 is not subject of this EC-Type Examination Certificate.



Translation

1st Supplement

(Supplement in accordance with Directive 94/9/EC Annex III number 6)

to the EC-Type Examination Certificate BVS 05 ATEX E 143 X

Equipment: gas sensors type IDS 0001, IDS 0002, IDS 0011 or IDS 0012
and gas detection heads type ITR 0001, ITR 0002 or ITR 0010,
ISH 0001, ISH 0002 or ISH 0010

Manufacturer: Dräger Safety AG & Co. KGaA

Address: D - 23560 Lübeck

Description

The Essential Health and Safety Requirements with respect to the measuring function for explosion protection are assured by application of:

EN 61779-1:2000 + A11:2004
EN 61779-4:2000
EN 50271:2001

This supplement to the EC-type examination certificate covers the measuring function for methane, propane and ethylene with the measuring range 0 - 100 % LEL.

This supplement to the EC-type examination certificate covers devices with software version 2.03.

Test report

Test report PFG-no. 41300506P dated 24/10/2006

Special conditions for safe use

- See EC-type examination certificate BVS 05 ATEX E 143 X
- Junction boxes used for the gas sensors IDS 00** shall have a sufficient mechanical stability in order to avoid mutual excitations of box and sensor if exposed to vibrations.
- The interconnection of the gas sensors type IDS 0002 or IDS 0012 or gas detection heads type ISH 0001, ISH 0002 or ISH 0010 with a control unit shall be certified separately.

EXAM BBG Prüf- und Zertifizier GmbH

Bochum, dated 27/10/2006

Signed: Jockers

Signed: Kiesewetter

Certification body

Special services unit



Translation

2nd Supplement

(Supplement in accordance with Directive 94/9/EC Annex III number 6)

**to the EC-Type Examination Certificate
BVS 05 ATEX E 143 X**

Equipment: gas sensors type IDS 0002 or IDS 0012
and gas detection heads type ISH 0001, ISH 0002 or ISH 0010

Manufacturer: Dräger Safety AG & Co. KGaA

Address: D - 23560 Lübeck

Description

This supplement to the EC-type examination certificate covers the interconnection of the gas sensors or gas detection heads with control units type Polytron SE Ex.
The Essential Health and Safety Requirements with respect to the measuring function for explosion protection are assured by application of:

EN 61779-1:2000 + A11:2004
EN 61779-4:2000
EN 50271:2001

This supplement to the EC-type examination certificate covers the measuring function for methane, propane and ethylene with the measuring range 0 - 100 % LEL.

This supplement to the EC-type examination certificate covers gas sensors and gas detection heads with software version 2.03.

Test report

Test report PFG-no. 41300506P dated 24/10/2006

Special conditions for safe use

- See 1. supplement to the EC-type examination certificate BVS 05 ATEX E 143 X

EXAM BBG Prüf- und Zertifizier GmbH

Bochum, dated 27/10/2006

Signed: Jockers

Certification body

Signed: Kiesewetter

Special services unit



Translation
3rd Supplement

(Supplement in accordance with Directive 94/9/EC Annex III number 6)

to the EC-Type Examination Certificate
BVS 05 ATEX E 143 X

Equipment: gas sensors type IDS 0001, IDS 0002, IDS 0011 or IDS 0012
 and gas detection heads type ITR 0001, ITR 0002 or ITR 0010,
 ISH 0001, ISH 0002 or ISH 0010

Manufacturer: Dräger Safety AG & Co. KGaA

Address: D-23560 Lübeck

Description

The Essential Health and Safety Requirements with respect to the measuring function for explosion protection are assured by application of:

EN 61779-1:2000 + A11:2004
EN 61779-4:2000

This supplement to the EC-type examination certificate covers for operation in gas category propane the measuring function for the gases und vapours i-butane, n-butane, n-pentane, n-hexane, n-octane, n-nonane and i-propanol in the measuring range 0 - 100 % LEL and ethanol and ethyl acetate in the measuring range 0 - 70 % LEL.

This supplement to the EC-type examination certificate covers for operation in gas category ethylene the measuring function for the gases und vapours propylene, toluene, acetone and ethyl acetate in the measuring range 0 - 100 % LEL and methanol in the measuring range 0 - 70 % LEL.

This supplement to the EC-type examination certificate covers devices with software version 2.07.

Test report

Test report PFG-no. 41300506P NI dated 19/05/2008

Special conditions for safe use

- see 1. supplement to the EC-type examination certificate BVS 05 ATEX E 143 X

DEKRA EXAM GmbH
 Bochum, dated 19/05/2008

Signed: Jockers

Signed: Kiesewetter

 Certification body

 Special services unit



Translation

4th Supplement

(Supplement in accordance with Directive 94/9/EC Annex III number 6)

to the EC-Type Examination Certificate

BVS 05 ATEX E 143 X

Equipment: gas sensors type IDS 0002 or IDS 0012
and gas detection heads type ISH 0001, ISH 0002 or ISH 0010

Manufacturer: Dräger Safety AG & Co. KGaA

Address: D-23560 Lübeck

Description

This supplement to the EC-type examination certificate covers the interconnection of the gas sensors or gas detection heads with control units type Polytron SE Ex.

The Essential Health and Safety Requirements with respect to the measuring function for explosion protection are assured by application of:

EN 61779-1:2000 + A11:2004
EN 61779-4:2000

This supplement to the EC-type examination certificate covers for operation in gas category propane the measuring function for the gases and vapours i-butane, n-butane, n-pentane, n-hexane, n-octane, n-nonane and i-propanol in the measuring range 0 - 100 % LEL and ethanol and ethyl acetate in the measuring range 0 - 70 % LEL.

This supplement to the EC-type examination certificate covers for operation in gas category ethylene the measuring function for the gases and vapours propylene, toluene, acetone and ethyl acetate in the measuring range 0 - 100 % LEL and methanol in the measuring range 0 - 70 % LEL.

This supplement to the EC-type examination certificate covers gas sensors and gas detection heads with software version 2.07.

Test report

Test report PFG-no. 41300506P N1 dated 19/05/2008

Special conditions for safe use

- see 1. supplement to the EC-type examination certificate BVS 05 ATEX E 143 X

DEKRA EXAM GmbH

Bochum, dated 19/05/2008

Signed: Jockers

Signed: Kiesewetter

Certification body

Special services unit



5th Supplement

(Supplement in accordance with Directive 94/9/EC Annex III number 6)

to the EC-Type Examination Certificate BVS 05 ATEX E 143 X

Equipment: Gas detection sensors types IDS 0001, IDS 0002, IDS 0011, IDS 0012 and Gas sensing heads types ITR 0001, ITR 0002, ITR 0010, ISH 0001, ISH 0002, and ISH 0010

Manufacturer: Dräger Safety AG & Co. KGaA

Address: 23560 Lübeck, Germany



Description

The gas detection sensors now also comply with the current status of the standards applicable and may modified according to the documents stated in the pertinent Test and Assessment Report.

The Essential Health and Safety Requirements of the modified equipment are assured by compliance with:

EN 60079-0:2006	General requirements
EN 60079-1:2004	Flameproof Enclosure 'd'
EN 60079-7:2003	Increased Safety 'e'
EN 61241-0:2006	General requirements
EN 61241-1:2004	Protection by Enclosures

The marking of the equipment shall include the following:

 **II 2G Ex d IIC T6** (Type IDS 0001, IDS 0002, IDS 0011, IDS 0012, ITR 0010 and ISH 0010)
 **II 2G Ex de IIC T6** (Type ITR 0001, ITR 0002, ISH 0001 and ISH 0002)
II 2D Ex tD A21 IP6X T80°C

Special conditions for safe use

The gas detection sensors of the following types: IDS 0001, IDS 0011, IDS 0002, and IDS 0012, as well as the gas sensing heads of the following types: ITR 0001, ISH 0001, ITR 0002 and ISH 0002 are suitable for use in ambient temperature ranges of -40 °C to +65 °C.

The gas sensing heads type ITR 0010 and type ISH 0010 are suitable for use in ambient temperature ranges of -40 °C to +60 °C.

The gas detection sensors type IDS 0001 and type IDS 0002 (NPT thread) are suitable to be attached to an enclosure of the type of protection Flameproof Enclosure 'd', if there free volume does not exceed two litres and if the reference pressure is lower than 20 bar. The mechanical strength of the attachment and the inspection of the connecting thread regarding aspects of explosion protection and construction have to be carried out as part of the approval of the equipment to which the sensor will be attached.

Page 1 of 2 of BVS 05 ATEX E 143 X / N5

This certificate may only be reproduced in its entirety and without change.
 DEKRA EXAM GmbH Dinnendahlstrasse 9 44809 Bochum Germany Phone +49 234/3696-105 Fax +49 234/3696-110 E-mail za-exam@dekra.com
 (until 31.03.2007 EXAM BBG Prüf- und Zertifizier GmbH)



The gas detection sensors type IDS 0011 and type IDS 0012 (metric thread) are suitable to be attached to an enclosure of the type of protection Increased Safety 'e'. The mechanical strength and the compliance with the degree of protection IP6X have to be ensured of the as part of the approval of the electrical equipment intended for the attachment. If the sensor is attached to an enclosure of type of protection Increased Safety 'e', the clearance and creepage distances have to meet the requirements stated in 4.3 (Table 1) of EN 60079-7 or 4.4 and 4.5 of EN 60079-7. The wiring and the connecting of the sensor conductors have to be carried out mechanically protected according to 4.2, 4.3, 4.5.2, 4.6.1, 4.8 and 4.9 of EN 60079-7 and have to consider the temperature resistance of the conductors.

The sensors have to be properly screwed into the enclosure wall and to be fastened against accidental loosening. The sensor enclosure attached has to be connected to the potential equalisation of the enclosure attached in an electrostatically conductive manner (contact resistance < 10⁶ Ohm). If a potential equalisation is necessary, it has to be ensured by the attachment.

The measuring function for the purpose of explosion protection according to Annex II section 1.5.5 of Directive 94/9/EC is not subject of this supplement.

Test and assessment report

BVS PP 05.2107 EG as of 23.03.2009

DEKRA EXAM GmbH

Bochum, dated 23rd March 2009

Signed: Simanski

Signed: U. Hauke

Certification body

Special services unit

We confirm the correctness of the translation from the German original.
In the case of arbitration only the German wording shall be valid and binding.

44809 Bochum, 23rd March 2009
BVS-Kr /Ld / Her A 20080911

DEKRA EXAM GmbH

Certification body

Special services unit



Translation

(1) 6. Supplement to the EC-Type Examination Certificate

- (2) Equipment and protective systems intended for use in potentially explosive atmospheres - Directive 94/9/EC Supplement accordant with Annex III number 6
- (3) No. of EC-Type Examination Certificate: **BVS 05 ATEX E 143 X**
- (4) Equipment: **gas sensors type IDS 0001, IDS 0002, IDS 0011, IDS 0012 and gas detection heads type ITR 0001, ITR 0002, ITR 0010, ISH 0001, ISH 0002, ISH 0010**
- (5) Manufacturer: **Dräger Safety AG & Co. KGaA**
- (6) Address: **D-23560 Lübeck**
- (7) The design and construction of this equipment and any acceptable variation thereto are specified in the appendix to this supplement.
- (8) The certification body of DEKRA EXAM GmbH, notified body no. 0158 in accordance with Article 9 of the Directive 94/9/EC of the European Parliament and the Council of 23 March 1994, certifies that this equipment has been found to comply with the Essential Health and Safety Requirements relating to the design and construction of equipment and protective systems intended for use in potentially explosive atmospheres, given in Annex II to the Directive. The examination and test results are recorded in the test report PFG-no. 41300506P NII.
- (9) The Essential Health and Safety Requirements are assured by compliance with:
- EN 60079-29-1:2007**
EN 50271:2001
- This supplement to the EC-type examination certificate covers the measuring function for the gases and vapours listed in the 1. and 3. supplement to this EC-type examination certificate.
This supplement to the EC-type examination certificate covers devices with software version 2.11.
- (10) If the sign "X" is placed after the certificate number, it indicates that the equipment is subject to special conditions for safe use specified in the appendix to this certificate.
- (11) This supplement to the EC-Type Examination Certificate relates only to the design, examination and tests of the specified equipment in accordance to Directive 94/9/EC. Further requirements of the Directive apply to the manufacturing process and supply of this equipment. These are not covered by this certificate.
- (12) The marking of the equipment shall include the following:

Not changed

DEKRA EXAM GmbH
Bochum, dated 27. May 2011

Signed: Simanski

Certification body

Signed: Kiesewetter

Special services unit



(13) Appendix to

(14) **6. Supplement to the EC-Type Examination Certificate
BVS 05 ATEX E 143 X**

(15) 15.1 Subject and type

gas sensors type IDS 0001, IDS 0002, IDS 0011, IDS 0012
and gas detection heads type ITR 0001, ITR 0002, ITR 0010, ISH 0001, ISH 0002, ISH 0010

15.2 Description

This supplement to the EC-type examination certificate concerns re-testing according to EN 60079-29-1, modifications of the design and the accessory weather guard. The equipment can be modified according to the descriptive documents as mentioned in the pertinent test report.

15.3 Parameters

See EC-type examination certificate BVS 05 ATEX E 143 X and supplement 5

(16) Test and assessment report

PFG-no. 41300506P NII as of 27.05.2011

(17) Special conditions for safe use

- See 1. supplement to the EC-type examination certificate BVS 05 ATEX E 143 X

We confirm the correctness of the translation from the German original.
In the case of arbitration only the German wording shall be valid and binding.

DEKRA EXAM GmbH
44809 Bochum, 27. May 2011
PFG-Kie/Bre

Certification body

Special services unit



Translation

(1) 7th Supplement to the EC-Type Examination Certificate

- (2) Equipment and protective systems intended for use in potentially explosive atmospheres - Directive 94/9/EC Supplement accordant with Annex III number 6
- (3) No. of EC-Type Examination Certificate: **BVS 05 ATEX E 143 X**
- (4) Equipment: **Gas sensor types IDS0001 resp. IDS0002 resp. IDS0011 resp. IDS0012 and gas sensing heads type ITR 0001 resp. ITR0002 resp. ITR 0010 resp. ISH0001 resp. ISH 0002 resp. ISH 0010**
- (5) Manufacturer: **Dräger Safety AG & Co. KGaA**
- (6) Address: **Revalstraße 1, 23560 Lübeck, Germany**
- (7) The design and construction of this equipment and any acceptable variation thereto are specified in the appendix to this supplement.
- (8) The certification body of DEKRA EXAM GmbH, notified body no. 0158 in accordance with Article 9 of the Directive 94/9/EC of the European Parliament and the Council of 23 March 1994, certifies that this equipment has been found to comply with the Essential Health and Safety Requirements relating to the design and construction of equipment and protective systems intended for use in potentially explosive atmospheres, given in Annex II to the Directive. The examination and test results are recorded in the test and assessment report BVS PP 05.2107 EG.
- (9) The Essential Health and Safety Requirements are assured by compliance with:
- EN 60079-0:2009 General requirements**
EN 60079-1:2007 Flameproof enclosure
EN 60079-7:2007 Increased safety
EN 60079-31:2009 Protection by enclosures „t“
- (10) If the sign "X" is placed after the certificate number, it indicates that the equipment is subject to special conditions for safe use specified in the appendix to this certificate.
- (11) This supplement to the EC-Type Examination Certificate relates only to the design, examination and tests of the specified equipment in accordance to Directive 94/9/EC. Further requirements of the Directive apply to the manufacturing process and supply of this equipment. These are not covered by this certificate.
- (12) The marking of the equipment shall include the following:

II 2G Ex d IIC T6 Gb
 (Type IDS 0001, IDS 0002, IDS 0011, IDS 0012, ITR 0010 and ISH 0010)

 **II 2G Ex de IIC T6 Gb**
 (Type ITR 0001, ITR 0002, ISH 0001 and ISH 0002)

II 2D Ex tb IIIC T80°C Db
IP6X

DEKRA EXAM GmbH
 Bochum, dated 06th August 2012

Signed: Dr. Eickhoff

Certification body

Signed: Dr. Wittler

Special services unit

(13) Appendix to

(14) **7th Supplement to the EC-Type Examination Certificate
BVS 05 ATEX E 143 X**

(15) 15.1 Subject and type

Gas sensors type IDS 00**	1	: measuring value in mA
	2	: measuring value in mV
	0	: Variant flameproof enclosure with 3/4" NPT thread
	1	: Variant increased safety with M25 thread
Gas sensings head type I** 00**	01	: Bartec housing in type of protection increased safety
	02	: Hawke housing in type of protection increased safety
	10	: Cortem housing in type of protection flameproof enclosure
	SH	: measuring value in mV
	TR	: measuring value in mA

15.2 Description

The gas sensors and gas sensing heads are also in compliance with the actual valid standard editions. They can be manufactured according to the documentation listed in the related test and assessment report.

15.3 Parameters

Unchanged

(16) Test and assessment report

BVS PP 05.2107 EG as of 06.08.2012

(17) Special conditions for safe use Installation instructions

The gas sensor types IDS0001 resp. IDS0002 resp. IDS0011 resp. IDS0012 and gas sensing heads type ITR 0001 resp. ITR0002 resp. ISH0001 resp. ISH 0002 are usable for an ambient temperature range of -40 °C up to +65 °C.

The gas sensing heads type ITR 0010 resp. type ISH 0010 are usable for an ambient temperature range of -40 °C up to +60 °C.

The gas sensor types IDS 0001 and IDS 0002 (NPT thread) shall be connected to enclosures type of protection flameproof "d" whose internal free volume does not exceed 2 litres and whose reference pressure does not exceed 20 bar.

The mechanical strength of the assembly as well as the flameproof properties of the connecting NPT thread shall be verified by the type test of the enclosure to which the sensor is attached.

The gas sensor types IDS 0011 and IDS 0012 (metric thread) are suitable for mounting to enclosures of type of protection increased safety "e".

The mechanical strength and the IP 6X grade of protection of the assembly shall be verified by the type test of the enclosure to which the sensor is attached.



The clearances and creepage distances shall comply with the requirements of 4.3 (Table 1) and 4.4 of EN 60079-7.

The wiring and the connection of the wires of the sensor shall be performed according to 4.5, 4.7.2 and 4.8 of EN 60079-7 mechanical protected and corresponding to the temperature resistance of the wire.

The threaded joint between the gas sensor and enclosure shall be properly mounted and protected against unintended loosening.

After assembly, the sensor housing shall be connected to potential ground of the enclosure in an electrostatically conductive manner (contact resistance <math>< 10^6 \text{ Ohm}</math>). If equipotential bonding is necessary, it shall be provided by the assembly.

We confirm the correctness of the translation from the German original.
In the case of arbitration only the German wording shall be valid and binding.

DEKRA EXAM GmbH
44809 Bochum, 04.09.2012
BVS-Ld/Ar A 20110288



Certification body



Special services unit



Translation

8th Supplement to the EC-Type Examination Certificate

- (2) Equipment and protective systems intended for use in potentially explosive atmospheres - Directive 94/9/EC Supplement accordant with Annex III number 6
- (3) No. of EC-Type Examination Certificate: **BVS 05 ATEX E 143 X**
- (4) Equipment: **Gas sensor types IDS0001, IDS0002, IDS0011 and IDS0012 and gas sensing heads type ITR 0001, ITR0002, ITR 0010, ISH001, ISH 0002 and ISH 0010**
- (5) Manufacturer: **Dräger Safety AG & Co. KGaA**
- (6) Address: **Revalstraße 1, 23560 Lübeck, Germany**
- (7) The design and construction of this equipment and any acceptable variation thereto are specified in the appendix to this supplement.
- (8) The certification body of DEKRA EXAM GmbH, notified body no. 0158 in accordance with Article 9 of the Directive 94/9/EC of the European Parliament and the Council of 23 March 1994, certifies that this equipment has been found to comply with the Essential Health and Safety Requirements relating to the design and construction of equipment and protective systems intended for use in potentially explosive atmospheres, given in Annex II to the Directive. The examination and test results are recorded in the Test and Assessment Report BVS PP 05.2107 EG.
- (9) The Essential Health and Safety Requirements are assured by compliance with:
 - EN 60079-0:2012 + A11:2013 General requirements**
 - EN 60079-1:2014 Flameproof enclosure "d"**
 - EN 60079-7:2015 Increased safety "e"**
 - EN 60079-31:2014 Protection by enclosure "t"**
- (10) If the sign "X" is placed after the certificate number, it indicates that the equipment is subject to special conditions for safe use specified in the appendix to this certificate.
- (11) This supplement to the EC-Type Examination Certificate relates only to the design, examination and tests of the specified equipment in accordance to Directive 94/9/EC. Further requirements of the Directive apply to the manufacturing process and supply of this equipment. These are not covered by this certificate.
- (12) The marking of the equipment shall include the following:

II 2G Ex db IIC T6 Gb
 (Type IDS 0001, IDS 0002, IDS 0011, IDS 0012, ITR 0010 and ISH 0010)

 **II 2G Ex db eb IIC T6 Gb**
 (Type ITR 0001, ITR 0002, ISH 0001 and ISH 0002)

II 2D Ex tb IIIC T80°C Db

DEKRA EXAM GmbH
 Bochum, dated 2016-03-30

Signed: Simanski

Signed: Dr. Wittler

Certification body

Special services unit



Page 1 of 4 of BVS 05 ATEX E 143 X / N8
 This certificate may only be reproduced in its entirety and without any change.

DEKRA EXAM GmbH, Dinnendahlstrasse 9, 44809 Bochum, Germany,
 telephone +49.234.3696-105, Fax +49.234.3696-110, zs-exam@dekra.com

(13) Appendix to

(14) **8th Supplement to the EC-Type Examination Certificate
BVS 05 ATEX E 143 X**

(15) 15.1 Subject and type

Gas sensors type IDS 00**	1	: measuring value in mA
	2	: measuring value in mV
	0	: Variant flameproof enclosure with 3/4" NPT thread
	1	: Variant flameproof enclosure with M25 thread
Gas sensings head type I** 00**	01	: Bartec housing in type of protection increased safety
	02	: Hawke housing in type of protection increased safety
	10	: Cortem housing in type of protection flameproof enclosure
	SH	: measuring value in mV
	TR	: measuring value in mA

15.2 Description

The sensor types IDS 0001, IDS 0011, IDS 0002 and IDS 0012 in type of protection flameproof enclosure "d" serve for the measurement of combustible gases and vapours under atmospheric conditions. The sensors are suitable for operation in ambient temperatures from -40 °C to +65 °C.

The power of the sensors is supplied by non-intrinsically safe circuits via a cast resin cable feed through. The sensor types IDS 0011 and IDS 0012 are designed for mounting to enclosures with type of protection increased safety "e" that are certified for this purpose. The sensor types IDS 0001 and IDS 0002 are designed for mounting to enclosures with type of protection flameproof enclosure "d". The mechanical strength of the assembly as well as the flameproof properties of the connecting thread shall be verified by the type test of the enclosure to which the sensor is attached.

The gas sensing head types ITR 0001 and ITR 0002 resp. ISH 0001 and ISH 0002 consist of a gas sensor of type IDS 0011 resp. IDS 0012 and an attached enclosure of type of protection increased safety "e". The gas sensing head types ITR 0001, ITR 0002, ISH 0001 and ISH 0002 serve for the measurement of combustible gases and vapours under atmospheric conditions and are suitable for operation in ambient temperature ranges from -40 °C to +65 °C.

The gas sensing head types ITR 0010 and ISH 0010 consist of a gas sensor of type IDS 0001 resp. IDS 0002 and an attached enclosure of type of protection flameproof enclosure "d". The gas sensing head types ITR 0010 and type ISH 0010 serve for the measurement of combustible gases and vapours under atmospheric conditions and are suitable for operation in ambient temperature ranges from -40 °C to +60 °C

Reason for this supplement is the update of the used standards.

Listing of all components used referring to older standards

Subject and type	Certificate	Standards
Housing	PTB 08 ATEX 1062 U	EN 60079-0:2012 EN 60079-7:2007
Terminals	PTB 99 ATEX 3117 U	EN 60079-0:2004 EN 60079-7:2007
Terminals	PTB 98 ATEX 3129 U	EN 60079-0:2012 EN 60079-7:2007
Terminals	DEMKO 14 ATEX 1338 U	EN 60079-0:2012 EN 60079-7:2007

15.3 Parameters

15.3.1 Supply of the gas sensors and gas sensing heads

Voltage	up to	30 V
Power	up to	2 W

15.3.2 Temperatures

Ambient temperature range for gas sensor	type IDS 0001, type IDS 0011, type IDS 0002, type IDS 0012 and	
gas sensing heads	type ITR 0001, type ISH 0001, type ITR 0002, type ISH 0002	-40 °C up to + 65 °C

Ambient temperature range for gas sensing heads type ITR 0010 and type ISH 0010		-40 °C up to + 60 °C
---	--	----------------------

Gas sensor type IDS 0001, type IDS 0011, type IDS 0002 and type IDS 0012		
Maximum temperature of cast resin at maximum allowed power and ambient temperature	75	°C
Maximum temperature of supply leads at maximum allowed power and ambient temperature	70	°C

(16) Test and Assessment Report

BVS PP 05.2107 EG as of 2016-03-30

(17) Special conditions for safe use

- 17.1 The gas sensor types IDS0001 resp. IDS0002 resp. IDS0011 resp. IDS0012 and gas sensing heads type ITR 0001 resp. ITR0002 resp. ISH0001 resp. ISH 0002 are usable for an ambient temperature range of -40 °C up to +65 °C.
- 17.2 The gas sensing heads type ITR 0010 resp. type ISH 0010 are usable for an ambient temperature range of -40 °C up to +60 °C.
- 17.3 The gas sensor types IDS 0001 and IDS 0002 (NPT thread) shall be connected to enclosures type of protection flameproof "d" whose internal free volume does not exceed 2 litres and whose reference pressure does not exceed 20 bar. The mechanical strength of the assembly as well as the flameproof properties of the connecting NPT thread shall be verified by the type test of the enclosure to which the sensor is attached.
- 17.4 The gas sensor types IDS 0011 und IDS 0012 (metric thread) are suitable for mounting to enclosures of type of protection increased safety "e". The mechanical strength and the IP 6X grade of protection of the assembly shall be verified by the type test of the enclosure to which the sensor is attached.
- 17.5 The clearances and creepage distances shall comply with the requirements of 4.3 (Table 1) and 4.4 of EN 60079-7. The wiring and the connection of the wires of the sensor shall be performed according to 4.5, 4.7.2 and 4.8 of EN 60079-7 mechanical protected and corresponding to the temperature resistance of the wire.
- 17.6 The threaded joint between the gas sensor and enclosure shall be properly mounted and protected against unintended loosening.
- 17.7 After assembly, the sensor housing shall be connected to potential ground of the enclosure in an electrostatically conductive manner (contact resistance < 10⁰ Ohm). If equipotential bonding is necessary, it shall be provided by the assembly.



Page 3 of 4 of BVS 05 ATEX E 143 X / N8
This certificate may only be reproduced in its entirety and without any change.

DEKRA EXAM GmbH, Dinnendahlstrasse 9, 44809 Bochum, Germany,
telephone +49.234.3696-105, Fax +49.234.3696-110, zs-exam@dekra.com



We confirm the correctness of the translation from the German original.
In the case of arbitration only the German wording shall be valid and binding.

DEKRA EXAM GmbH
44809 Bochum, 2016-03-30
BVS-Pe/Nu A 20140928

Certification body

Special services unit



Page 4 of 4 of BVS 05 ATEX E 143 X / N8
This certificate may only be reproduced in its entirety and without any change.

DEKRA EXAM GmbH, Dinnendahlstrasse 9, 44809 Bochum, Germany,
telephone +49.234.3696-105, Fax +49.234.3696-110, zs-exam@dekra.com

(1) **EU-TYPE EXAMINATION CERTIFICATE**



- (2) Equipment and Protective Systems intended for use in Potentially Explosive Atmosphere - **Directive 2014/34/EU**
- (3) EU-Type Examination Certificate Number

TÜV 19 ATEX 8433 X

Issue: 00

- (4) **Equipment:** Infrared gas transmitter used for stationary, continuous monitoring of the concentration of carburetted, combustible gases and vapours in the ambient air type Ixx 00xx
- (5) **Manufacturer:** Dräger Safety AG & Co. KGaA
- (6) **Address:** Revalstr. 1
23560 Lübeck, Germany
- (7) This product and any acceptable variation thereto are specified in the schedule to this certificate and the documents therein referred to.
- (8) The TÜV Rheinland Zertifizierungsstelle für Explosionsschutz of TÜV Rheinland Industrie Service GmbH, Notified Body No. 0035 in accordance with Article 21 of the Council Directive 2014/34/EU of 26th February 2014, certifies this product which has been found to comply with the Essential Health and Safety Requirements relating to the design and construction of equipment and protective systems intended for use in potentially explosive atmosphere, given in Annex II to the Directive.

The examination and test results are recorded in the confidential report 557/Ex8433.00/19
- (9) Compliance with the Essential Health and Safety Requirements, with the exception of those listed in the schedule of this certificate, has been assessed by reference to:

EN 60079-29-1:2016

EN 50271:2018

- (10) If the sign "X" is placed after the certificate number, it indicates that the equipment is subject to special conditions for safe use specified in the schedule to this certificate.
- (11) This EU-Type Examination Certificate relates only to the design and specification for construction of the equipment or protective system. It does not cover the process for actual manufacture or supply of the equipment or protective system, for which further requirements of the directive are applicable.
- (12) The marking of the equipment shall include the following:



II (2) G

TÜV Rheinland Zertifizierungsstelle für Explosionsschutz

Cologne, 2019-11-19

Dipl.-Ing. Christian Mehrhoff



This EU-Type Examination Certificate without signature and stamp shall not be valid.
This EU-Type Examination Certificate may be circulated only without alteration. Extracts or alterations are subject to approval by the TÜV Rheinland Industrie Service GmbH, TÜV Rheinland Group, Am Grauen Stein 51105 Köln
Tel. +49 (0) 221 806 0 Fax. + 49 (0) 221 806 114

www.tuv.com



IECEX - Approval

		<h2 style="margin: 0;">IECEX Certificate of Conformity</h2>	
<p>INTERNATIONAL ELECTROTECHNICAL COMMISSION IEC Certification Scheme for Explosive Atmospheres <small>for rules and details of the IECEX Scheme visit www.iecex.com</small></p>			
Certificate No.:	IECEX BVS 05.0011X	issue No.:	3
Status:	Current	<div style="border: 1px solid black; padding: 2px;"> <small>Certificate history:</small> Issue No. 3 (2016-4-6) Issue No. 2 (2012-8-9) Issue No. 1 (2009-3-23) Issue No. 0 (2005-11-23) </div>	
Date of Issue:	2016-04-06	Page 1 of 5	
Applicant:	Dräger Safety AG & Co. KGaA Revalstraße 1 23560 Lübeck Germany		
Electrical Apparatus:	Gas sensor types IDS0001, IDS0002, IDS0011 and IDS0012 and gas sensing heads type ITR 0001, ITR0002, ITR 0010, ISH0001, ISH 0002 and type ISH 0010 <small>Optional accessory:</small>		
Type of Protection:	Equipment protection by flameproof enclosures "d", Equipment dust ignition protection by enclosure "t", Equipment protection by increased safety "e"		
Marking:	Ex db IIC T6 Gb or Ex db eb IIC T6 Gb Ex tb IIIC T80°C Db		
Approved for issue on behalf of the IECEX Certification Body:	H.-Ch. Simanski		
Position:	Head of Certification Body		
Signature: <small>(for printed version)</small>			
Date:			
<ol style="list-style-type: none"> 1. This certificate and schedule may only be reproduced in full. 2. This certificate is not transferable and remains the property of the issuing body. 3. The Status and authenticity of this certificate may be verified by visiting the Official IECEX Website. 			
Certificate issued by:	<div style="display: flex; align-items: center;"> <div style="flex: 1;"> <p>DEKRA EXAM GmbH Dinnendahlstrasse 9 44809 Bochum Germany</p> </div> <div style="flex: 1; text-align: center;">  <p>DEKRA On the safe side.</p> </div> </div>		



IECEX Certificate of Conformity

Certificate No.: IECEx BVS 05.0011X

Date of Issue: 2016-04-06

Issue No.: 3

Page 2 of 5

Manufacturer: **Dräger Safety AG & Co. KGaA**
Revalstraße 1
23560 Lübeck
Germany

Additional Manufacturing location
(s):

This certificate is issued as verification that a sample(s), representative of production, was assessed and tested and found to comply with the IEC Standard list below and that the manufacturer's quality system, relating to the Ex products covered by this certificate, was assessed and found to comply with the IECEx Quality system requirements. This certificate is granted subject to the conditions as set out in IECEx Scheme Rules, IECEx 02 and Operational Documents as amended.

STANDARDS:

The electrical apparatus and any acceptable variations to it specified in the schedule of this certificate and the identified documents, was found to comply with the following standards:

IEC 60079-0 : 2011 Edition: 6.0	Explosive atmospheres - Part 0: General requirements
IEC 60079-1 : 2014-06 Edition: 7.0	Explosive atmospheres - Part 1: Equipment protection by flameproof enclosures "d"
IEC 60079-31 : 2013 Edition: 2	Explosive atmospheres - Part 31: Equipment dust ignition protection by enclosure "t"
IEC 60079-7 : 2015 Edition: 5.0	Explosive atmospheres – Part 7: Equipment protection by increased safety "e"

This Certificate does not indicate compliance with electrical safety and performance requirements other than those expressly included in the Standards listed above.

TEST & ASSESSMENT REPORTS:

A sample(s) of the equipment listed has successfully met the examination and test requirements as recorded in

Test Report:
[DE/BVS/ExTR06.0028/03](#)

Quality Assessment Report:
[DE/BVS/QAR06.0001/11](#)



IECEX Certificate of Conformity

Certificate No.: IECEX BVS 05.0011X

Date of Issue: 2016-04-06

Issue No.: 3

Page 3 of 5

Schedule

EQUIPMENT:

Equipment and systems covered by this certificate are as follows:

Subject and type
See Annex

Description

The sensor types IDS 0001, IDS 0011, IDS 0002 and IDS 0012 in type of protection flameproof enclosure "d" serve for the measurement of combustible gases and vapours under atmospheric conditions. The sensors are suitable for operation in ambient temperatures from -40 °C to +65 °C.

The power of the sensors is supplied by non-intrinsically safe circuits via a cast resin cable feed through. The sensor types IDS 0011 and IDS 0012 are designed for mounting to enclosures with type of protection increased safety "e" that are certified for this purpose. The sensor types IDS 0001 and IDS 0002 are designed for mounting to enclosures with type of protection flameproof enclosure "d". The mechanical strength of the assembly as well as the flameproof properties of the connecting thread shall be verified by the type test of the enclosure to which the sensor is attached.

The gas sensing head types ITR 0001 and ITR 0002 resp. ISH 0001 and ISH 0002 consist of a gas sensor of type IDS 0011 resp. IDS 0012 and an attached enclosure of type of protection increased safety "e". The gas sensing head types ITR 0001, ITR 0002, ISH 0001 and ISH 0002 serve for the measurement of combustible gases and vapours under atmospheric conditions and are suitable for operation in ambient temperature ranges from -40 °C to +65 °C.

The gas sensing head types ITR 0010 and ISH 0010 consist of a gas sensor of type IDS 0001 resp. IDS 0002 and an attached enclosure of type of protection flameproof enclosure "d". The gas sensing head types ITR 0010 and type ISH 0010 serve for the measurement of combustible gases and vapours under atmospheric conditions and are suitable for operation in ambient temperature ranges from -40 °C to +60 °C.

Listing of all components used referring to older standards

Subject and type	Certificate	Standards
Housing	IECEX PTB 09.0008 U ¹	IEC 60079-0:2011 Ed. 6 IEC 60079-7:2006 Ed. 4
Terminals	IECEX PTB 07.0007 U ¹	IEC 60079-0:2007 Ed. 5 IEC 60079-7:2006 Ed. 4
Terminals	IECEX PTB 04.0003 U ¹	IEC 60079-0:2011 Ed. 6 IEC 60079-7:2006 Ed. 4
Terminals	IECEX ULD 05.0008 U ¹	IEC 60079-0:2004 Ed. 4 IEC 60079-7:2001 Ed. 3

¹ No applicable technical differences

² Technical differences evaluated and found satisfactory

CONDITIONS OF CERTIFICATION: YES as shown below:

- The gas sensor types IDS0001 resp. IDS0002 resp. IDS0011 resp. IDS0012 and gas sensing heads type ITR 0001 resp. ITR0002 resp. ISH0001 resp. ISH 0002 are usable for an ambient temperature range of -40 °C up to +65 °C.
- The gas sensing heads type ITR 0010 resp. type ISH 0010 are usable for an ambient temperature range of -40 °C up to +60 °C.
- The gas sensor types IDS 0001 and IDS 0002 (NPT thread) shall be connected to enclosures type of protection flameproof "d" whose internal free volume does not exceed 2 litres and whose reference pressure does not exceed 20 bar. The mechanical strength of the assembly as well as the flameproof properties of the connecting NPT thread shall be verified by the type test of the enclosure to which the sensor is attached.
- The gas sensor types IDS 0011 and IDS 0012 (metric thread) are suitable for mounting to enclosures of type of protection increased safety "e". The mechanical strength and the IP 6X grade of protection of the assembly shall be verified by the type test of the enclosure to which the sensor is attached.
- The clearances and creepage distances shall comply with the requirements of 4.3 (Table 1) and 4.4 of IEC 60079-7. The wiring and the connection of the wires of the sensor shall be performed according to 4.5, 4.7.2 and 4.8 of IEC 60079-7 mechanical protected and corresponding to the temperature resistance of the wire.
- The threaded joint between the gas sensor and enclosure shall be properly mounted and protected against unintended loosening.
- After assembly, the sensor housing shall be connected to potential ground of the enclosure in an electrostatically conductive manner (contact resistance < 10⁵ Ohm). If equipotential bonding is necessary, it shall be provided by the assembly.



IECEx Certificate of Conformity

Certificate No.: IECEx BVS 05.0011X

Date of Issue: 2016-04-06

Issue No.: 3

Page 4 of 5

EQUIPMENT(continued):

Parameters

1. Supply of the gas sensors and gas sensing heads

Voltage	up to	30	V
Power	up to	2	W

2. Supply of the gas sensors and gas sensing heads

Ambient temperature range for gas sensor types IDS 0001, IDS 0002, IDS 0011 and IDS 0012 as well as gas sensing heads types ITR 0001, ITR 0002, ISH 0001 and ISH 0002 -40 °C to +65 °C

Ambient temperature range for gas sensing heads type ITR 0010 and type ISH 0010 -40 °C to +60 °C

Gas sensor types IDS 0001, IDS 0011, IDS 0002 and IDS 0012:

Maximum temperature of cast resin at maximum allowed power and ambient temperature 75 °C

Maximum temperature of supply leads at maximum allowed power and ambient temperature 70 °C



IECEX Certificate of Conformity

Certificate No.: IECEX BVS 05.0011X

Date of Issue: 2016-04-06

Issue No.: 3

Page 5 of 5

DETAILS OF CERTIFICATE CHANGES (for issues 1 and above):

- The updating of the applicable standards.
- Added types ITR 0010 and ISH 0010 with separately tested and certified flameproof enclosure IECEX CES 15.0012U.

Annex: [BVS_05_0011X_Dräger_Annex_issue_3.pdf](#)



IECEX Certificate of Conformity



Certificate No.: IECEX BVS 05.0011 X **issue No.:** 3
Annex
Page 1 of 1

Subject and type

Gas sensors type IDS 00**

- 1 : measuring value in mA
- 2 : measuring value in mV
- 0 : Variant flameproof enclosure with 3/4" NPT thread
- 1 : Variant flameproof enclosure with M25 thread

Gas sensings head type I** 00**

- 01 : Bartec housing in type of protection increased safety
- 02 : Hawke housing in type of protection increased safety
- 10 : Cortem housing in type of protection flameproof enclosure
- SH : measuring value in mV
- TR : measuring value in mA

UL - Approval

UL Online Certifications Directory

JTPD.E180059

Gas and Vapor Detection Equipment Classified for Use in Hazardous Locations

[Page Bottom](#)

Gas and Vapor Detection Equipment Classified for Use in Hazardous Locations

[See General Information for Gas and Vapor Detection Equipment Classified for Use in Hazardous Locations](#)

DRAGER SAFETY AG & CO KGAA

E180059

REVALSTRASSE 1
23560 LUEBECK, GERMANY

Class I, Groups A, B, C and D; Class II, Groups E, F and G.

Gas monitors, Models P3S (Polytron 3000), P3U (Polytron 7000). Intrinsicly safe when installed in accordance with Draeger Control Drawing SE20105.

Model MiniWarn. Intrinsicly safe when used with Draeger battery pack, Part Nos. 6408180, 6408120, 6408133, 6408116 and optionally with MiniWarn pump, Part No. 6408112. The monitor is not for use with an oxygen enriched atmosphere.

Gas sensors, Models IDS0001 and IDS0002.

Handheld gas detectors, Models Pac 1000, Pac 3000, Pac 5000, Pac 7000, intrinsicly safe when used with one of the following Lithium batteries: Panasonic Part No. CR123A, Energizer Part No. EL123 or EL123A, Varta/Powerone Part No. CR123A or Duracell Part No. 123 or 123 Photo.

Handheld gas detector, Model LQG 00xx Series, intrinsicly safe when used with manufacturer's battery pack designated ABT 00xx (provided with one of the following battery types: GP Type 180AAHC-NiMH, Energizer Type E91-LR6 or ANZI-15A, Energizer Type EN91-LR6 or ANZI-15A, Varta Type 4106 PowerOne LR6 or ANZI-15A) or manufacturer's rechargeable battery pack designated HBT 00xx.

Class I, Groups A, B, C, and D; Class II, Groups F and G.

Portable gas analyzer, Model Micropac. Intrinsicly safe when used with one self contained Lithium size "AA" battery manufactured by Sonnenschein Part No. SL760 or Tadaran Part No. TL760. The battery is nonuser replaceable.

Class I, Groups A, B, C and D.

Gas analyzer, Model CMS. Intrinsicly safe when used with four 1.5V size AA alkaline batteries.

Gas monitor, Model Multiwarn II. Intrinsicly safe when used with Draeger battery pack, Part No. 6408240, 8313353, 8315485 or 8315505. The monitor is not for use in an oxygen enriched atmosphere.

Gas monitor, Model X-am 7000. Intrinsicly safe when used with Draeger X-am 7000 NiMH, 4.8V, 3Ah or 6Ah battery packs or Draeger X-am 7000 Alkaline, 6V battery pack. The monitor is not for use in an oxygen enriched atmosphere.

Portable combustible gas and oxygen deficiency detector, Model Pac Ex 2, intrinsicly safe when used with manufacturer's rechargeable battery pack, Part No. 8316112 or alkaline pack, Part No. 8316111, containing four Duracell Part No. MN2400 or Energizer Part No. E92, Size AAA cells.

Portable pump for combustible gas and oxygen deficiency detector, Model Pac Ex2 Pump, intrinsicly safe when used three Duracell MN2400 or Energizer E92 AAA alkaline batteries.

Portable combustible gas, oxygen deficiency and toxic gas detector, Model X-am-3000, intrinsicly safe when used with manufacturer's rechargeable battery pack, Part Nos. 4543582 or 8317709, or alkaline pack, Part Nos. 4543583 or 8317716 containing four Duracell Part No. MN1500 or Energizer Part No. E91, Size AA, Type LR6, 1.5 V alkaline cells.

Last Updated on 2006-03-28

[Questions?](#)

[Notice of Disclaimer](#)

[Page Top](#)

Copyright © 2006 Underwriters Laboratories Inc.®

The appearance of a company's name or product in this database does not in itself assure that products so identified have been manufactured under UL's Follow-Up Service. Only those products bearing the UL Mark should be considered to be Listed and covered under UL's Follow-Up Service. Always look for the Mark on the product.

UL permits the reproduction of the material contained in the Online Certification Directory subject to the following conditions: 1. The Guide Information, Designs and/or Listings (files) must be presented in their entirety and in a non-misleading manner, without any manipulation of the data (or drawings). 2. The statement "Reprinted from the Online Certifications Directory with permission from Underwriters Laboratories Inc." must appear adjacent to the extracted material. In addition, the reprinted material must include a copyright notice in the following format: "Copyright © 2006 Underwriters Laboratories Inc.®"

An independent organization working for a safer world with integrity, precision and knowledge.



UL Online Certifications Directory

JTPD7.E180059 Gas and Vapor Detection Equipment Classified for Use in Hazardous Locations Certified for Canada

[Page Bottom](#)

Gas and Vapor Detection Equipment Classified for Use in Hazardous Locations Certified for Canada

[See General Information for Gas and Vapor Detection Equipment Classified for Use in Hazardous Locations Certified for Canada](#)

DRAGER SAFETY AG & CO KGAA

E180059

REVALSTRASSE 1
23560 LUEBECK, GERMANY

Class I, Groups A, B, C and D; Class II, Groups F and G.

Portable gas analyzer, Model Micropac. Intrinsically safe when used with one self contained Lithium size "AA" battery manufactured by Sonnenschein Part No. SL760 or Tadaran Part No. TL 760. The battery is nonuser replaceable.

Class I, Groups A, B, C and D; Class II, Groups E, F and G.

Gas sensors, Models IDS0001 and IDS0002.

Handheld Gas Detectors, Models Pac 1000, Pac 3000, Pac 5000, Pac 7000, intrinsically safe when used with one of the following Lithium batteries: Panasonic Part No. CR123A, Energizer Part No. EL123 or EL123A, Varta/Powerone Part No. CR123A, or Duracell Part No. 123 or 123 Photo.

Class I, Groups A, B, C and D.

Gas analyzer, Model CMS. Intrinsically safe when used with four 1.5V size AA alkaline batteries.

Classification Marking: Classified by Underwriters Laboratories Inc., as to fire, electrical shock and explosion hazards only.

[Last Updated](#) on 2006-03-28

[Questions?](#)

[Notice of Disclaimer](#)

[Page Top](#)

Copyright © 2006 Underwriters Laboratories Inc.®

The appearance of a company's name or product in this database does not in itself assure that products so identified have been manufactured under UL's Follow-Up Service. Only those products bearing the UL Mark should be considered to be Listed and covered under UL's Follow-Up Service. Always look for the Mark on the product.

UL permits the reproduction of the material contained in the Online Certification Directory subject to the following conditions: 1. The Guide Information, Designs and/or Listings (files) must be presented in their entirety and in a non-misleading manner, without any manipulation of the data (or drawings). 2. The statement "Reprinted from the Online Certifications Directory with permission from Underwriters Laboratories Inc." must appear adjacent to the extracted material. In addition, the reprinted material must include a copyright notice in the following format: "Copyright © 2006 Underwriters Laboratories Inc.®"

An independent organization working for a safer world with integrity, precision and knowledge.



CSA - Approval



Certificate of Compliance

Certificate: 1727857 (LR 97594)

Master Contract: 160220

Project: 1727857

Date Issued: 2006/02/10

Issued to: **Draeger Canada Limited**
7555 Danbro Cres
Mississauga, ON L5N 6P9
Canada
Attention: Mr. Sasha Vuksanov

The products listed below are eligible to bear the CSA Mark shown



Issued by: Mr. Glenn Black

Glenn Black

Authorized by: Patricia Pasemko, Operations
Manager

Patricia Pasemko

PRODUCTS

CLASS 4828 01 - SIGNAL APPLIANCES - - Combustible Gas Detection Instruments-For
Hazardous Locations

Class 1, Groups A, B, C and D:

Model IDS0001, input rated 10 to 30 V dc, 2 W, output rated 4-20 mA . May be used with splash guard p/n 68 10 796 and calibration adapter p/n 68 10 859

Model IDS0002, input rated 2 to 5 V dc, 1 W, output mv (Pellistor Mimic) electronics. Must be used with Draeger Regard Controller SE Ex channel card. May be used with splash guard p/n 68 10 796 and calibration adapter p/n 68 10 859.



Certificate: 1727857 (LR 97594)

Master Contract: 160220

Project: 1727857

Date Issued: 2006/02/10

APPLICABLE REQUIREMENTS

CSA Std C22.2 No. 30-M1986 - Explosion-Proof Enclosures for Use in Class 1 Hazardous Locations

CSA Std C22.2 No.152-M1984 - Combustible Gas Detection Instruments

CSA Std C22.2 No.157-92 - Intrinsically Safe and Non-Incendive Equipment for Use in Hazardous Locations

CSA Std C22.2 No.142-M1987 -Process Control Equipment

MARKINGS

- CSA Monogram;
- Submitter Identification;
- Model Number;
- Serial Number, Date Code or Month and Year of Manufacture;
- Hazardous locations designation;
- Electrical rating;
- Read Manual;
- Wording regarding for use in ambient temperatures of -40°C to +65°C;
- The words "Leads factory sealed ";



Supplement to Certificate of Compliance

Certificate: 1727857

Master Contract: 160220

The products listed, including the latest revision described below, are eligible to be marked in accordance with the referenced Certificate.

Product Certification History

Project	Date	Description
1727857	2006/02/10	Original Certification

Declaration of Conformity



EU-Konformitätserklärung EU-Declaration of Conformity



Dokument Nr. / Document No. SE20435-07

Wir / we Dräger Safety AG & Co. KGaA, Revalstraße 1, 23560 Lübeck, Germany

erklären in alleiniger Verantwortung, dass das Produkt
declare under our sole responsibility that the product

**Gassensor Typ IDS 00*1 (PIR 3000),
Gasesstransmitter Typ ITR 00** (PIR 3000 complete set)
Gassensor Typ IDS 00*2 (DrägerSensor IR)
Gasmesskopf Typ ISH 00** (DrägerSensor IR complete set)
Gas Sensor type IDS 00*1 (PIR 3000)
Gas Detection Transmitter type ITR 00** (PIR 3000 complete set)
Gas Sensor type IDS 00*2 (DrägerSensor IR)
Gas Detection Head type ISH 00** (DrägerSensor IR complete set)**

mit der EG-Baumusterprüfbescheinigung / Expertise
is in conformity with the EC-Type Examination Certificate /
Expertise

**BVS 05 ATEX E 143 X
TÜV 19 ATEX 8433 X
DNV GL 11480-14 HH**

ausgestellt von der notifizierten
Stelle mit der Kenn-Nr.
issued by the Notified Body
with Identification No.

DEKRA Testing and
Certification GmbH
Handwerkstr.15
D-70565 Stuttgart
0158

TÜV Rheinland Industrie
Service GmbH
Am Grauen Stein
D-51105 Köln
0035

DNV GL SE
Brooktorkai 18
D-20457 Hamburg
0098

und mit den folgenden Richtlinien unter Anwendung der aufgeführten Normen übereinstimmt
and is in compliance with the following directives by application of the listed standards

Bestimmungen der Richtlinie provisions of directive		Nummer sowie Ausgabedatum der Norm Number and date of issue of standard
2014/34/EU	ATEX-Richtlinie ATEX Directive	EN 60079-0:2012+A11:2013, EN 60079-1:2014, EN 60079-7:2015, EN 60079-31:2014, EN 60079-29-1:2016, EN 50271:2018
2014/90/EU	Schiffsausrüstungs-Richtlinie Marine Equipment Directive	EN 60079-0:2012+A11:2013, EN 60079-29-1:2016, IEC 60092-504:2016, IEC 60533:2015
2014/30/EU	EMV-Richtlinie EMC Directive	EN 50270:2015+AC:2016 susceptibility: type 2 emission: residential environment
2011/65/EU	RoHS-Richtlinie RoHS Directive	EN 50581:2012

Überwachung der Qualitäts-
sicherung Produktion durch
Surveillance of Quality Assurance
Production by

DEKRA Testing and
Certification GmbH
Handwerkstr.15
D-70565 Stuttgart
0158

DNV GL SE
Brooktorkai 18
D-20457 Hamburg
0098

Lübeck, 2019-11-21

Ort und Datum (jjjj-mm-tt)
Place and date (yyyy-mm-dd)

Dr. Marcus Romba
Head of Electronic Engineering
Head of Product Qualification
Safety Products
Research & Develop

Dräger Safety AG & Co. KGaA

Revalstraße 1

D-23560 Lübeck

Germany

Phone +49 451 8 82 - 27 94

Telefax +49 451 8 82 - 49 91

www.draeger.com

90 23 981 - GA 4677.501 en

© Dräger Safety AG & Co. KGaA

Edition 11 - July 2019 (Edition 01 - December 2005)

Subject to alteration